

SALES TOOL
ATTACH TABLE SERIES
FOR INTERNAL USE ONLY!

LAMMHULTS



PRODUCT SPECIFICATION

Legs of die-cast, texture powder coated aluminum. Alternatively texture powder coated in white or black with polished sides, at additional cost. Beams of extruded anodized recycled aluminum with transparent or black end caps. Choose between the beam ending 1cm or 31cm from the table's short side. Adjustable feet in black or orange acetal. NOTE! Tables are delivered with beams ending 31 cm from the table's short side and with black feet unless otherwise is specified in the order. Table top of 22 mm wooden board in the following versions:

- Veneer: natural ash or oak alt. stained ash with matching wooden edge.
- Linoleum: Forbo Furniture with matching edge.
- High Pressure Laminate: white, NCS S0502-G50Y, with matching plastic edge.
- Melamine: white, NCS S0502-G50Y, with matching plastic edge.

Other shapes, sizes and finishes on request. When ordering larger numbers of the

Additional
 Legs with raw grinded sides
 per leg
 High friction
 plastic glides
 Cable holder in white or
 anthracite felt, 120cm

NUMBER OF LEGS PER TABLE	
Rectangular tables	
Length 1600-4800	4
Length 4801-6300	6
Round tables	
Ø1000-1699	4
Ø1700-2000	3
Square tables	
1000x1000-2000x2000	4

Note! Round tables height 74cm, minimum Ø1700 or height 90cm, minimum Ø1800 are delivered with 3 legs. 4 legs on request.



TEXTURE POWDER COATS

801 Black	875 Graphite	891 White	894 Snow white
878 Zinc	853 RAL 5014 Dove blue	812 RAL 1032 Broom yellow	841 RAL 8014 Brown sepia

A SELECTION OF SHAPES AND SIZES

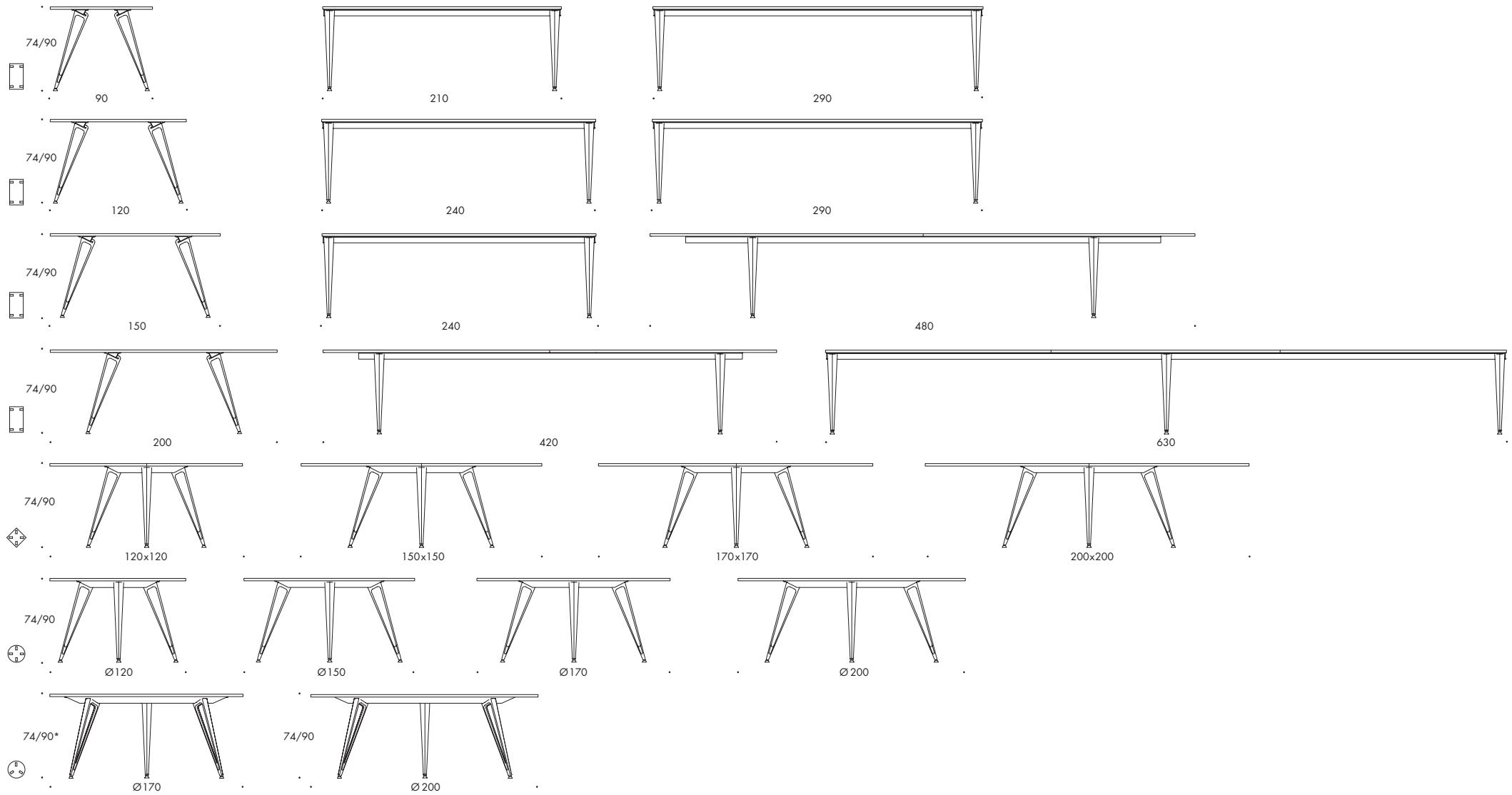

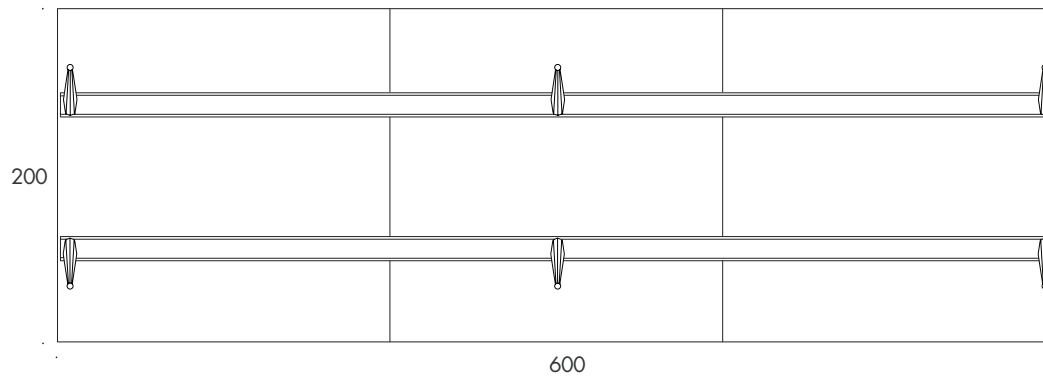
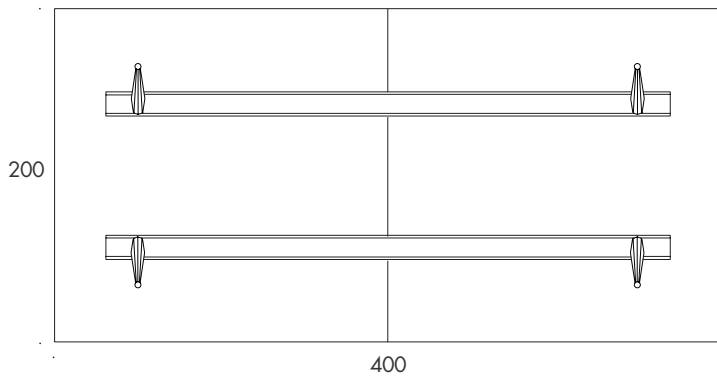
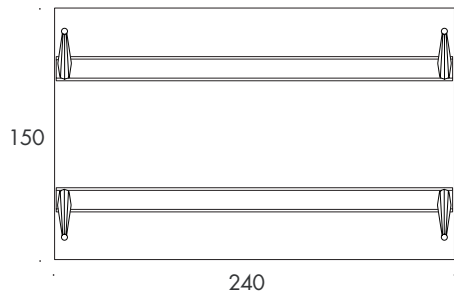
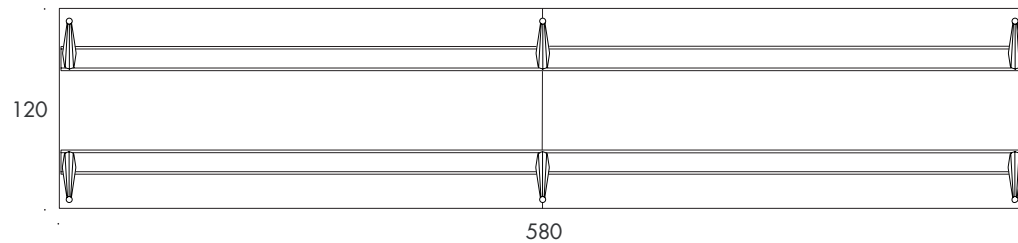
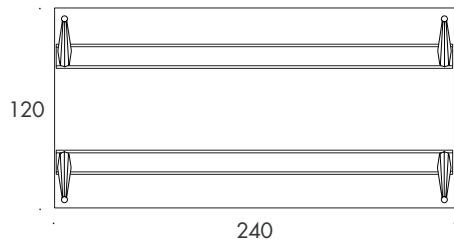
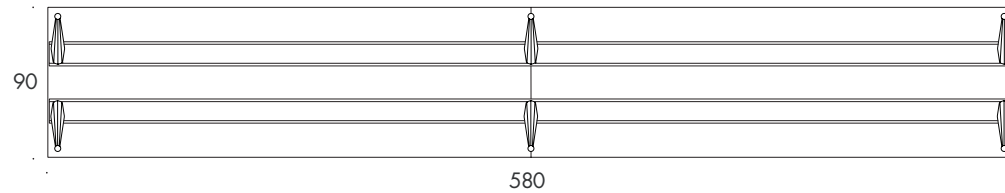
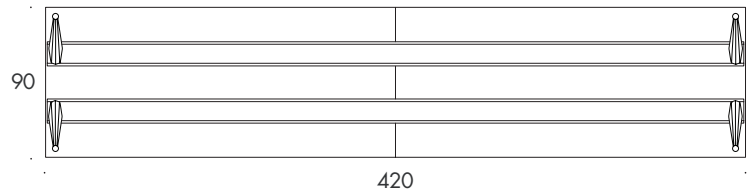

INSPIRATION & PROJECTS

Among others we have delivered to:

Ericsson, Sweden

SEB, Sweden

KPMG, Sweden

New Wave Group, Sweden

Tenden Lawfirm, Norway

AKA Hönefoss, Norway

Lindorff, Norway

Bibliotekenes Hus, Norway

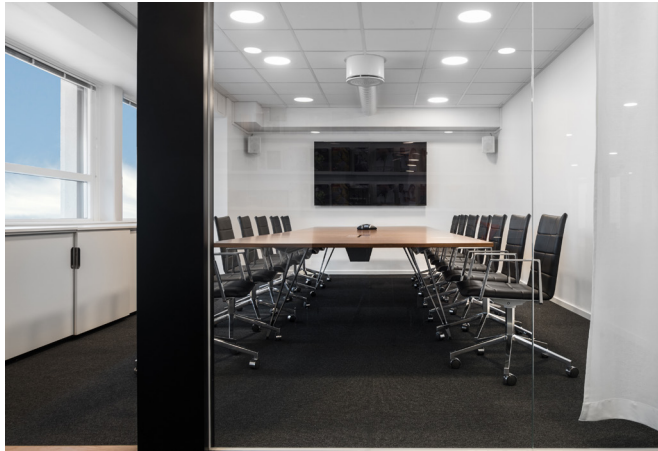



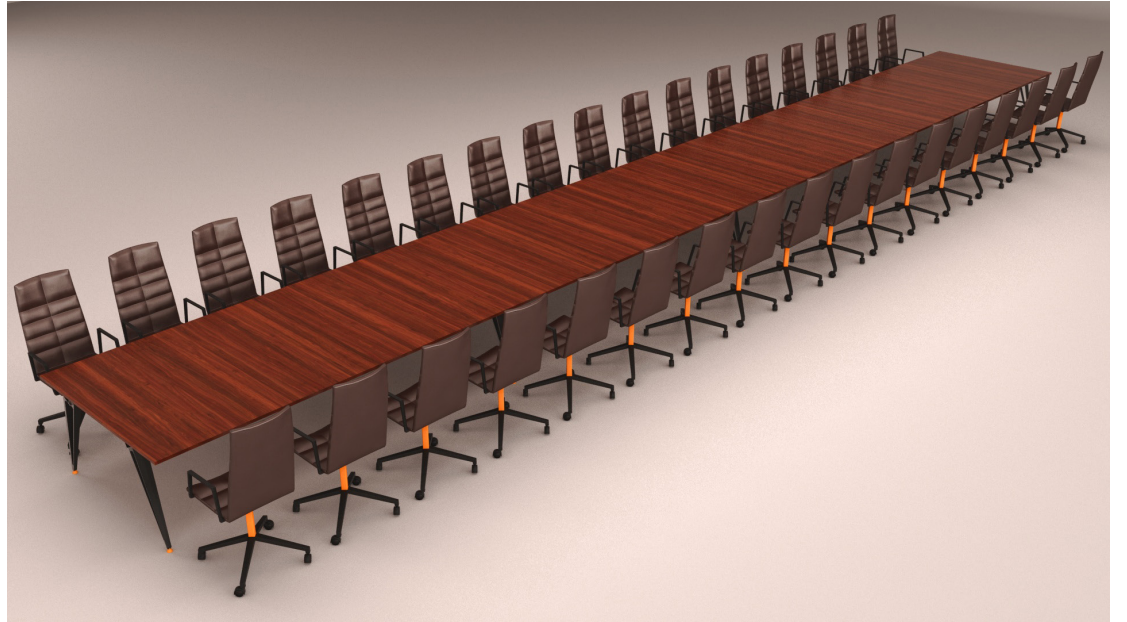

ATTACH WORK BENCH

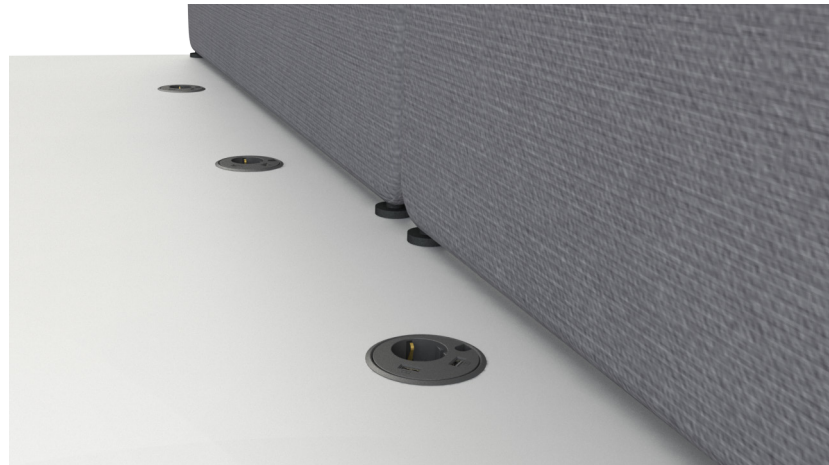

EXAMPLE OF VERSIONS THAT WE CAN OFFER - Round tables

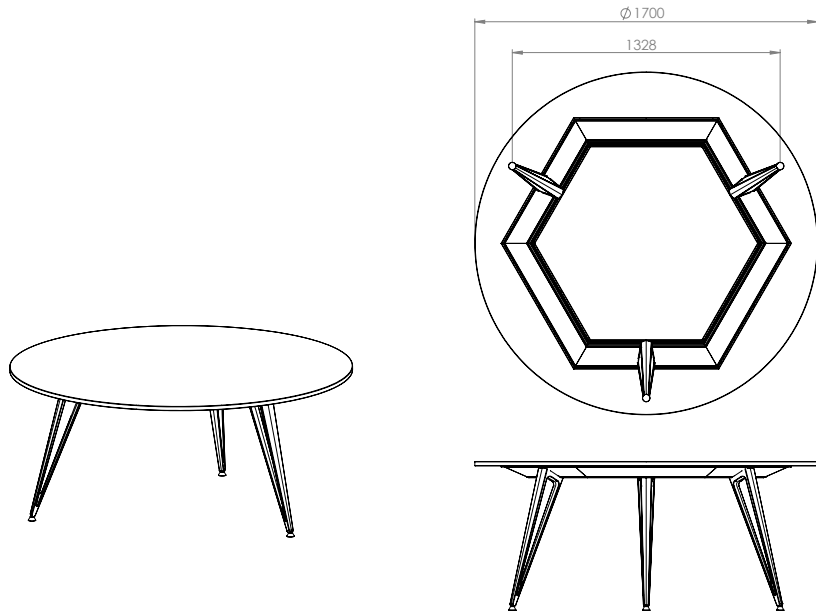
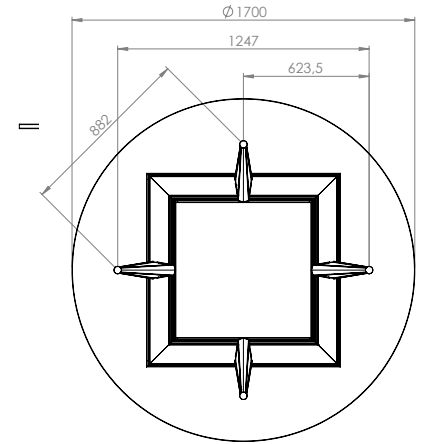
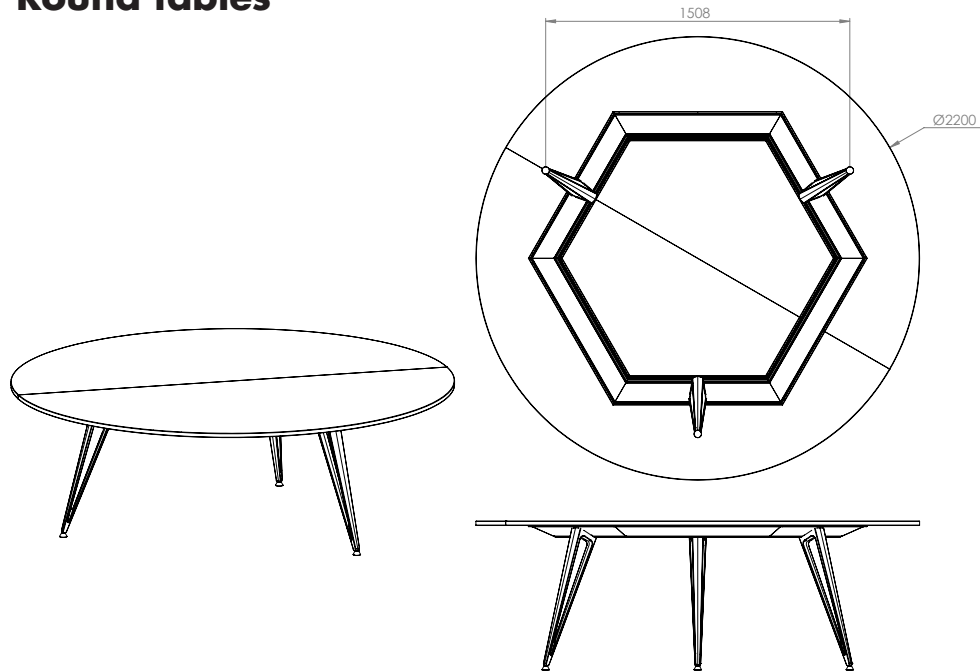

EXAMPLE OF VERSIONS THAT WE CAN OFFER - Oval tables



EXAMPLE OF VERSIONS THAT WE CAN OFFER - Boat shaped tables

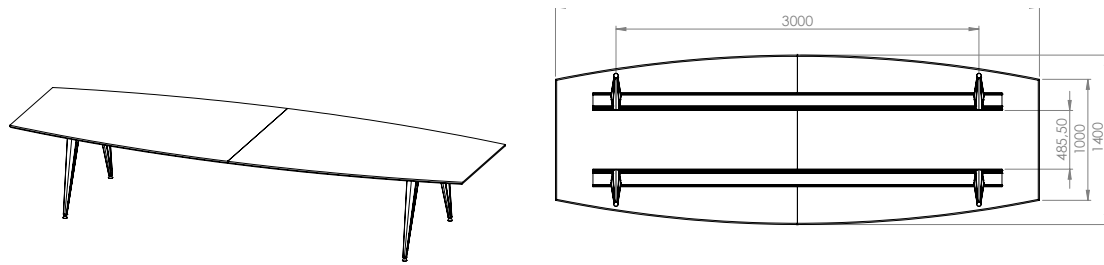

DETAIL A
SCALE 1:2

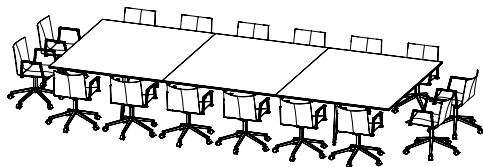
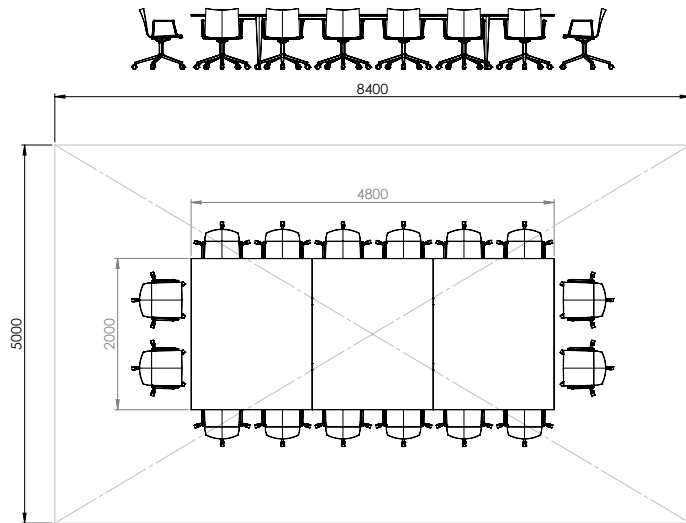
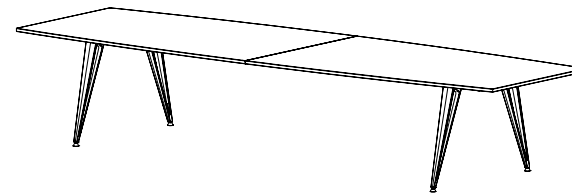
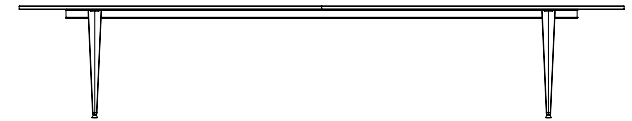
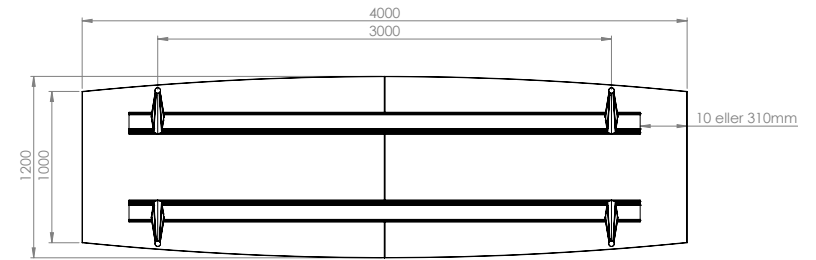

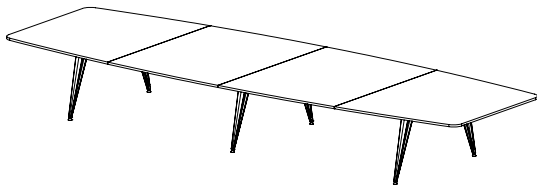
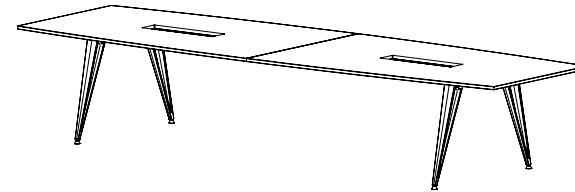
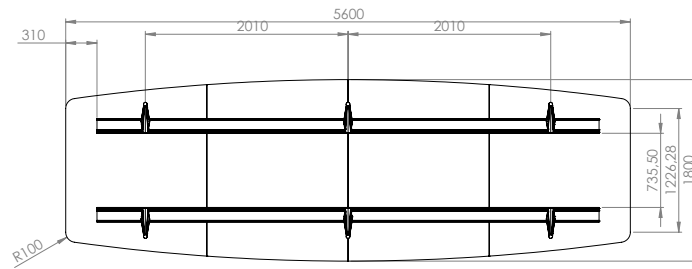
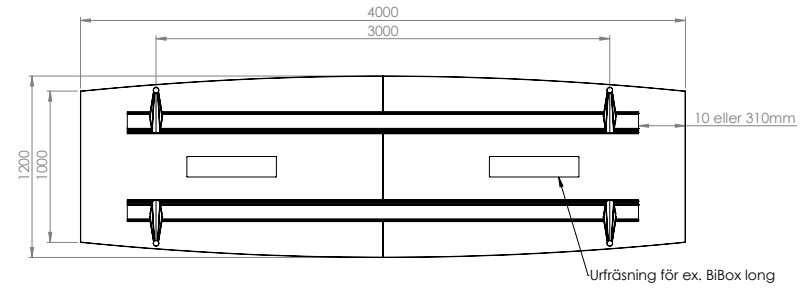
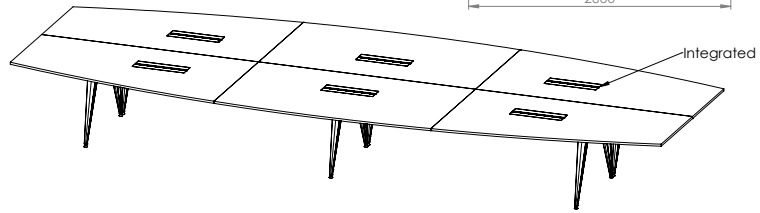
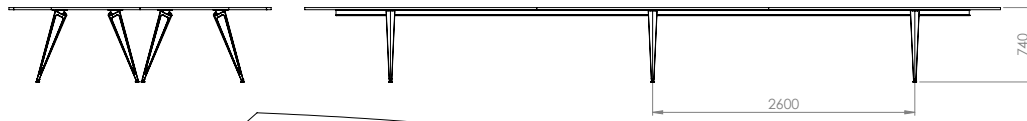
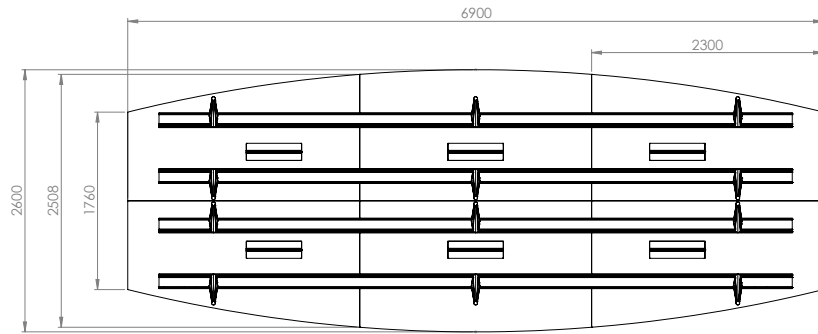

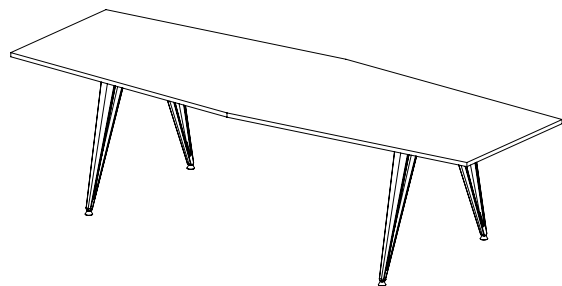
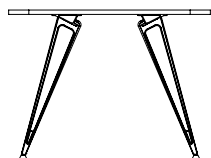
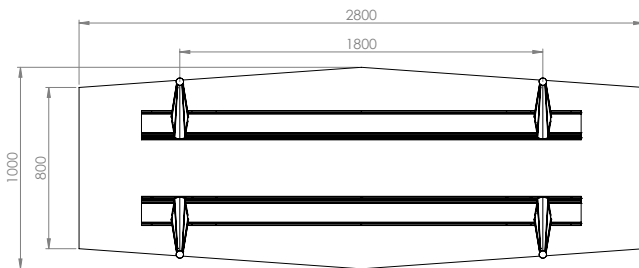
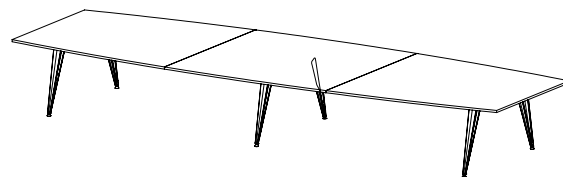
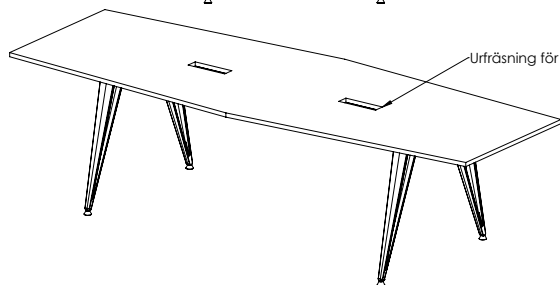
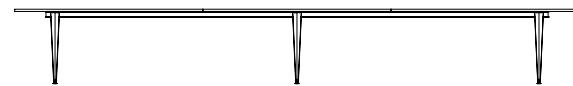
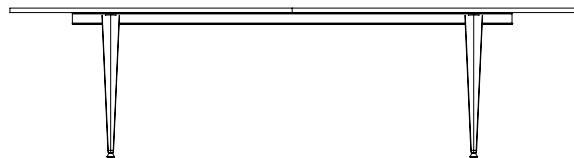
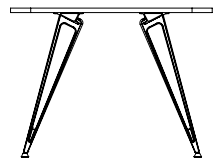
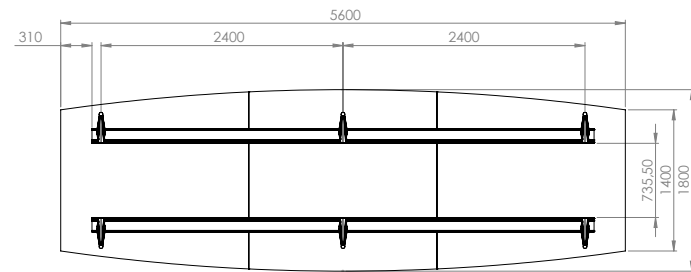
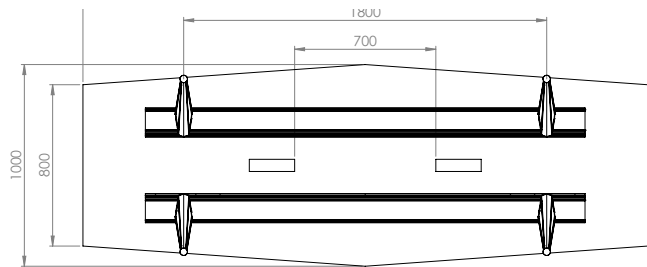

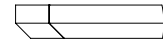
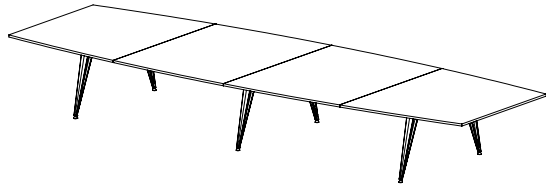
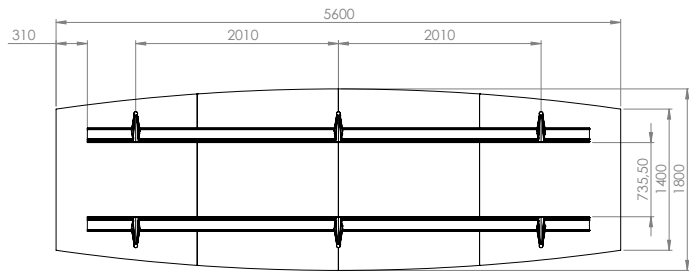

SCALE 1:2

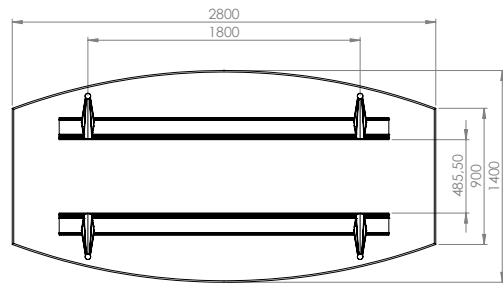
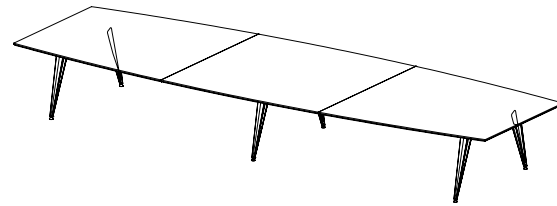
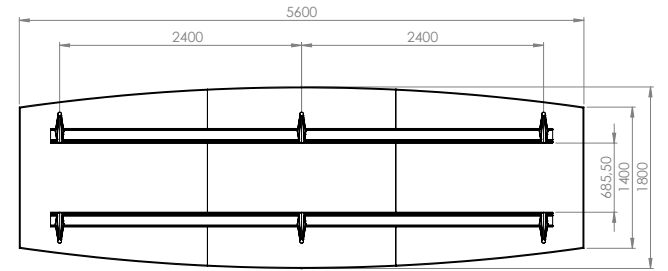

EXAMPLE OF VERSIONS THAT WE CAN OFFER - Rectangular tables

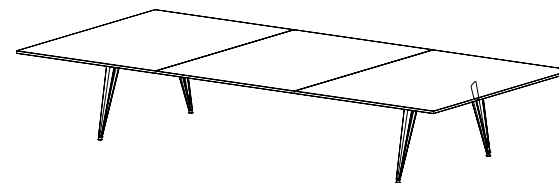
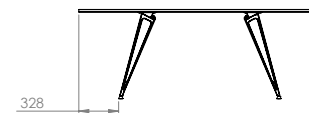
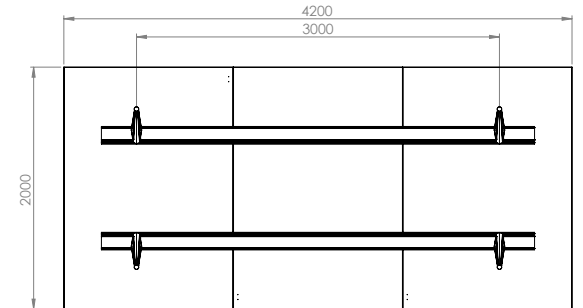
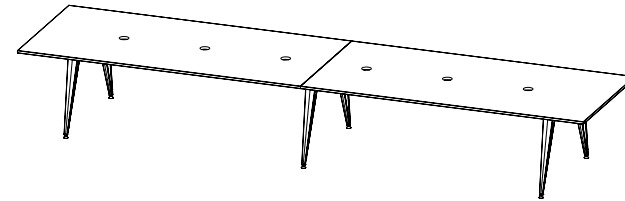
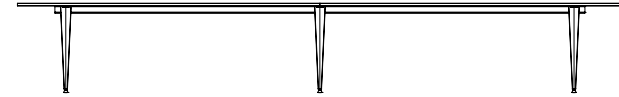
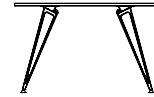
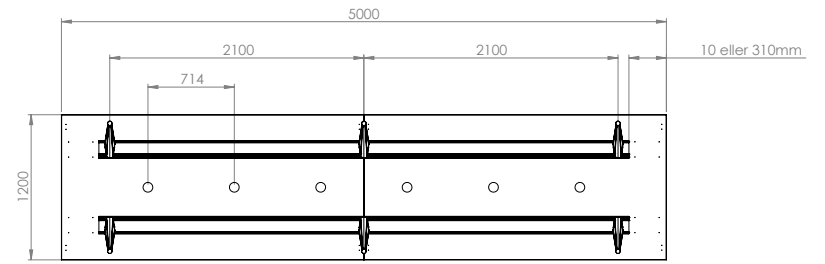
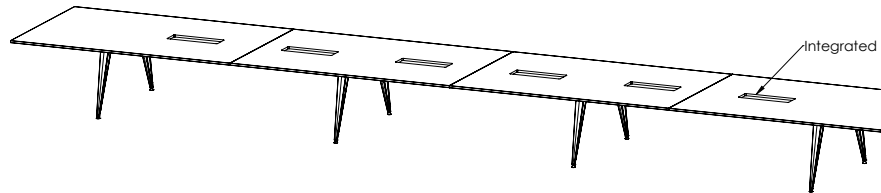
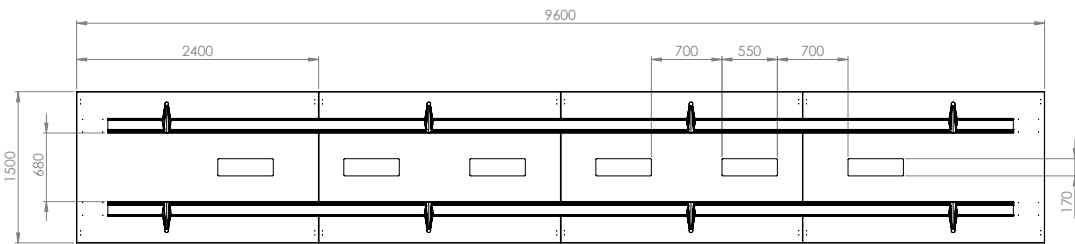
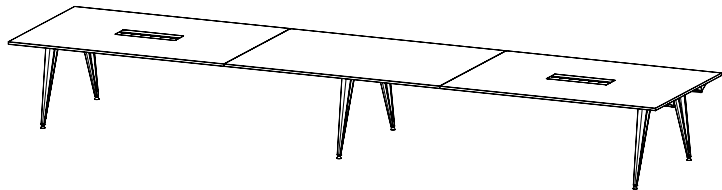
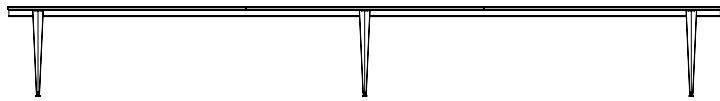
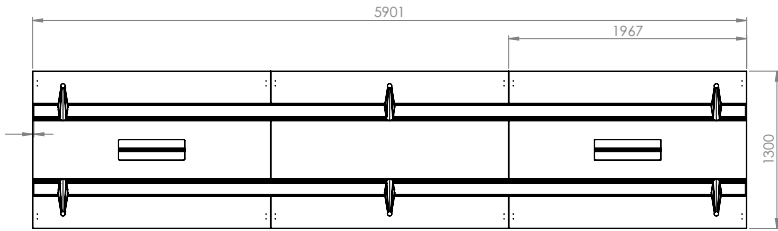

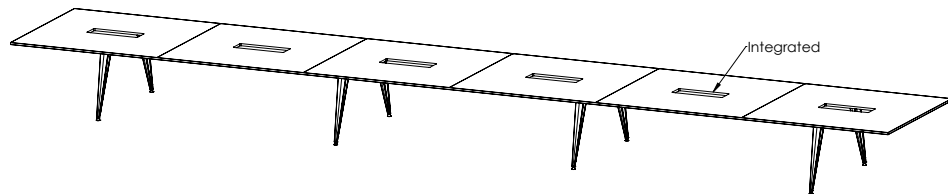
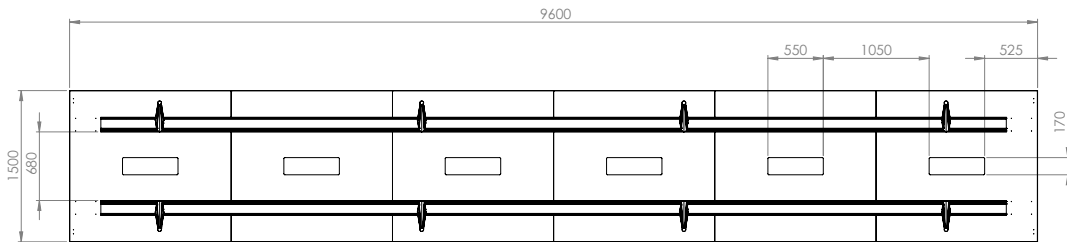
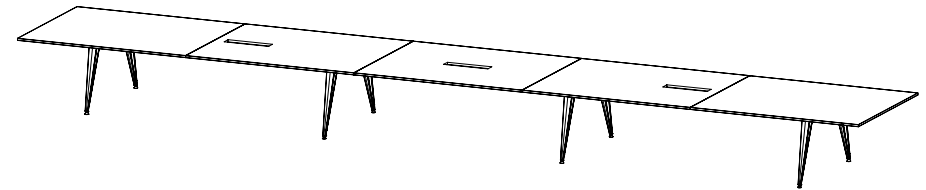
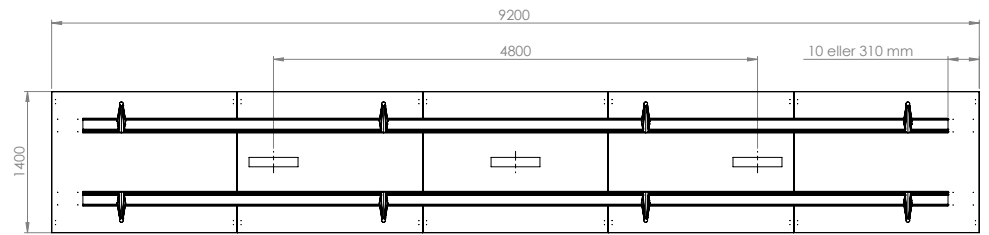
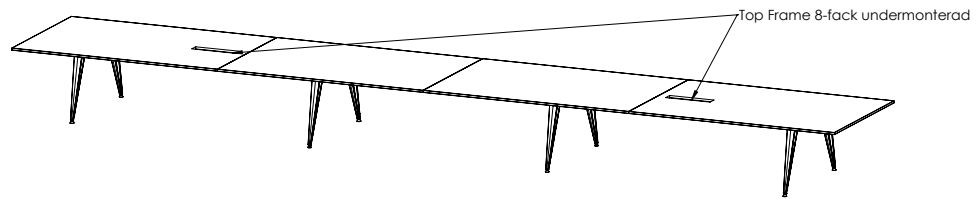
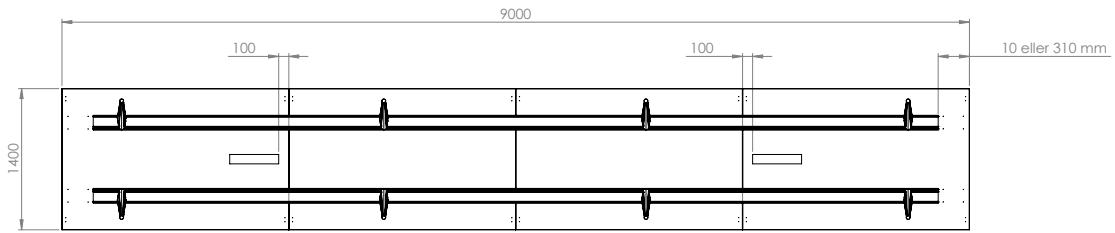

EXAMPLE OF VERSIONS THAT WE CAN OFFER - Square tables

Note that there is no room for a cable holder in his table.

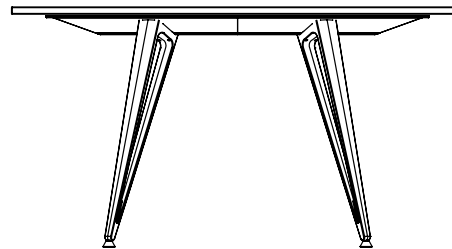
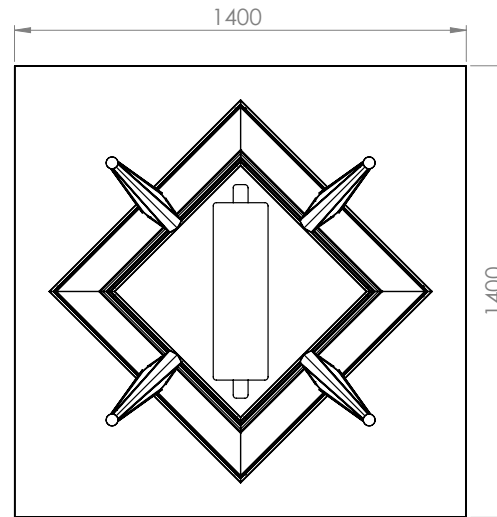
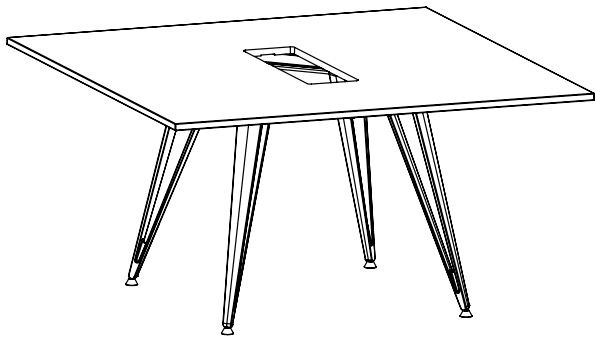

EXAMPLE OF VERSIONS THAT WE CAN OFFER - Configurations

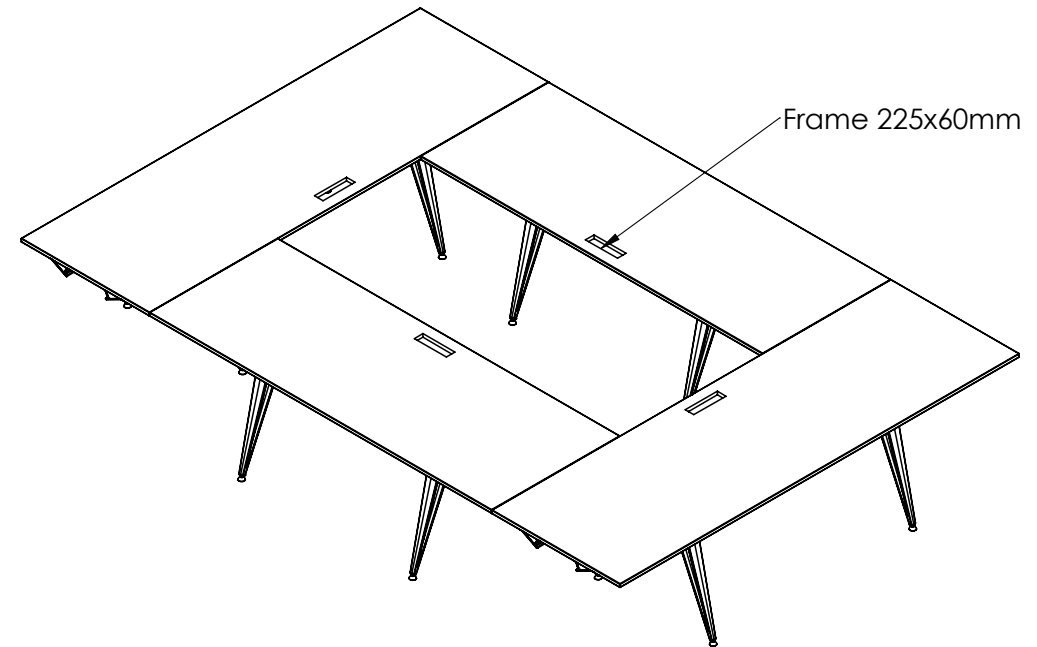
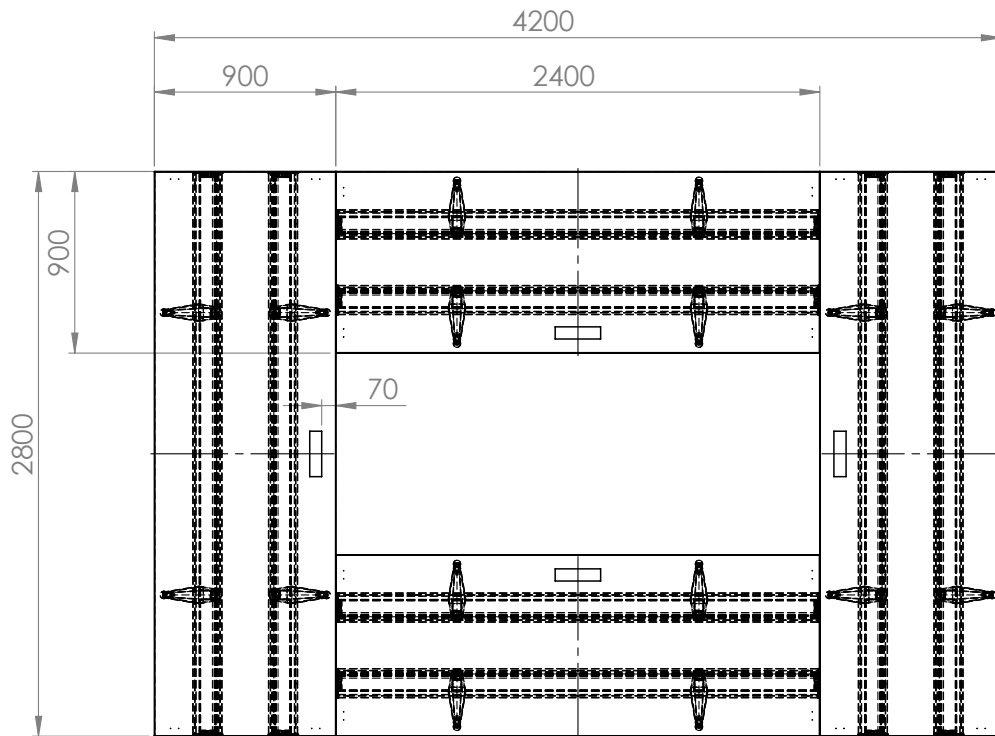
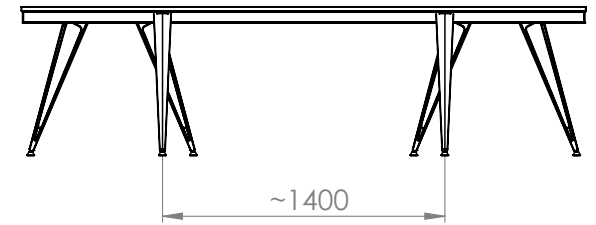
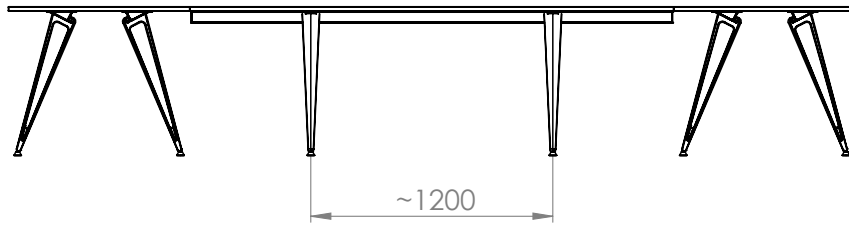

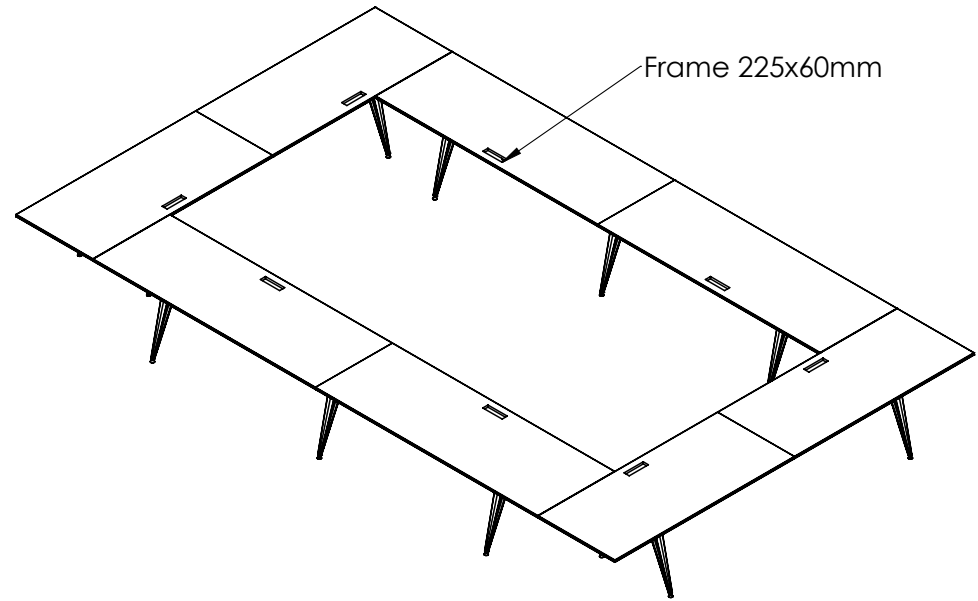
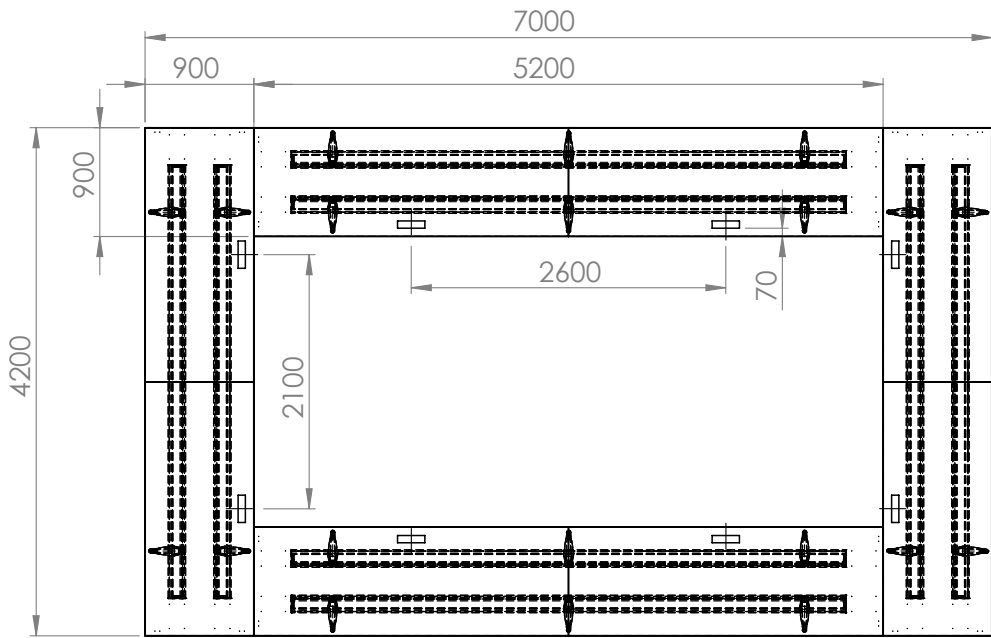
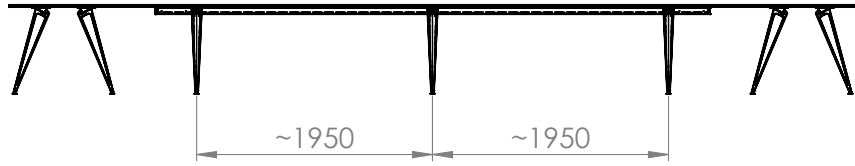

POWER AND COMMUNICATION PORTS

- BIBOX long. Dimensions 605 x 150 mm
 Excl. outlets
 Incl. outlets "Basic" = 4 power outlets & 4 CAT6, 4 USB alt. Incl. outlets "Plus" = 4 power outlets, 4 CAT6, 1 USB, 1 VGA, 1 AUDIO & 1 HDMI.

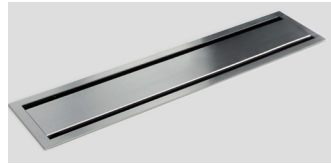

- BIBOX short. Dimensions 300 x 150 mm
 Excl. outlets
 Incl. outlets "Basic" = 3 outlets & 2 CAT6 alt. Incl. outlets "Plus" = 2 power outlet, 1 CAT6, 1 VGA, 1 AUDIO & 1 HDMI.



- FRAME Dimensions 242 x 73 mm
 Excl. outlets
 Incl. outlets "Basic" = 2 power outlet & 2 CAT6 alt. Incl. outlets "Plus" = 2 power outlet, 1 VGA, 1 AUDIO & 1 HDMI.



- INTEGRATED* Dimensions 550x170 mm
 Incl. white or anthracite cable management box in felt and 1 pce cable holder, 120cm.
 Excl. outlets
 Incl. outlets "Basic" = 4 power outlets & 4 CAT6, 1 VGA & 1 AUDIO alt. Incl. outlets "Plus" = 4 power outlets, 3 CAT6, 1 USB, 1 VGA, 1 AUDIO & 1 HDMI.

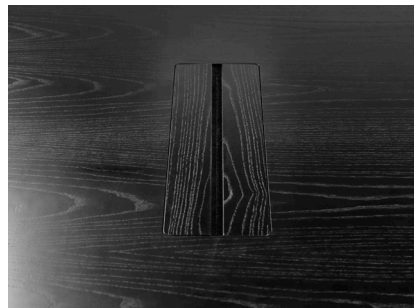

*The edges of the gap and lid come in raw MDF in combination with melamine table top and in clear lacquered MDF in combination with veener.
 In combination with tables height 90cm a minimum width of 100cm is required.

NOTE!

UK - all versions come with 1 power outlet less.

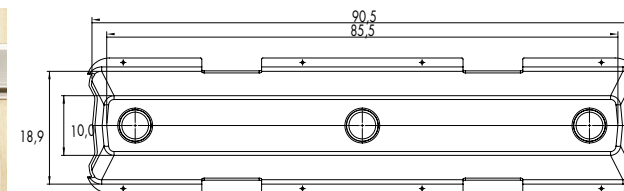

LIMITATIONS LEG PLACEMENT

Freestanding table

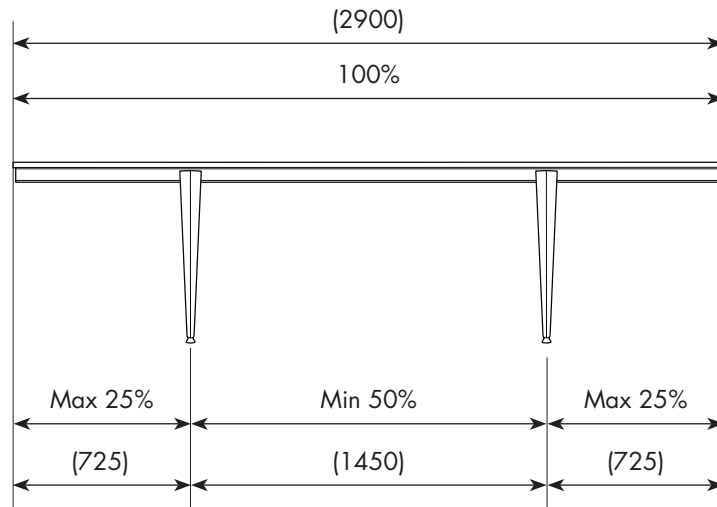

Linked table tops

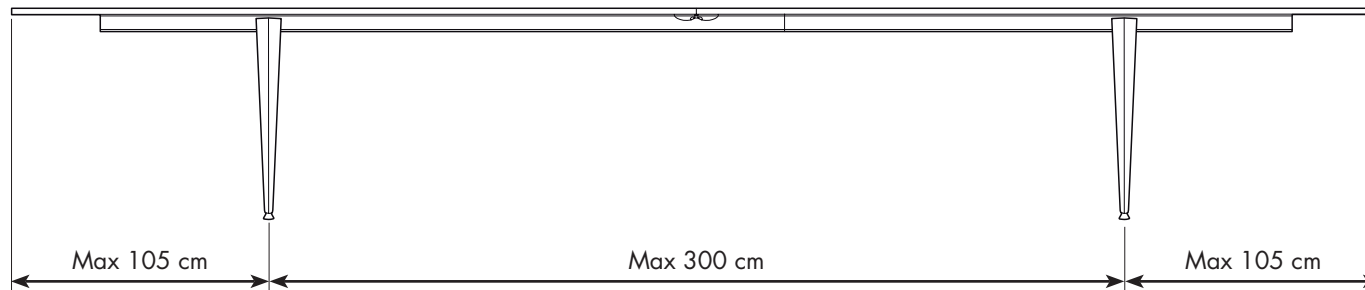

ATTACH OUTDOOR

Legs of die-cast, texture powder coated aluminum. Beams of extruded anodized recycled aluminum with transparent or black end caps. Adjustable feet in black acetal. Table top of wooden slats, 22x150mm, of natural alt. dark oiled Accoya. Bevelled edge.

Heights: 74, 90

Widths: 90, 120, 150

Lengths: 165, 180, 195, 210, 225, 240, 255, 270, 285, 300, 315

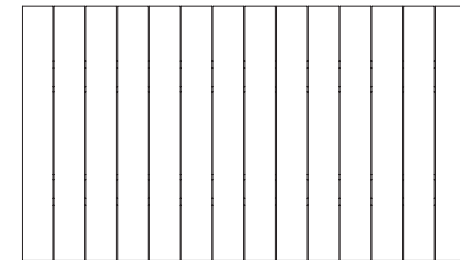
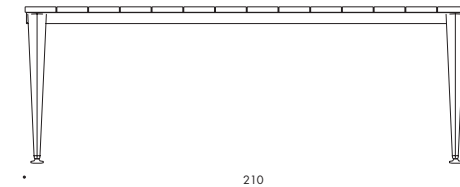
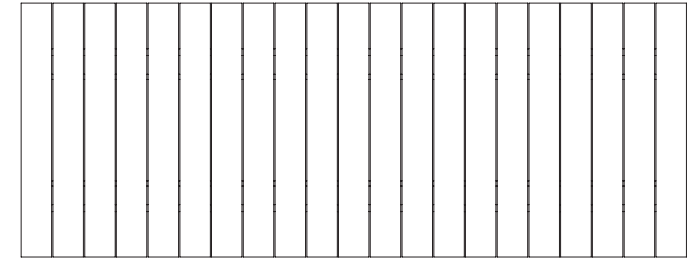
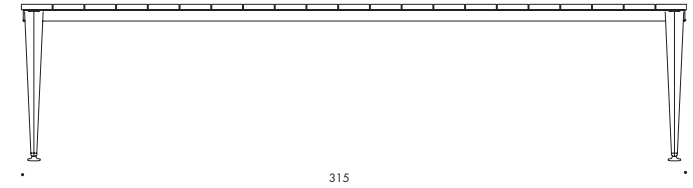
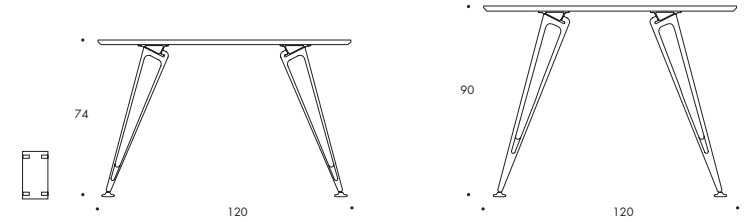

Dark stained

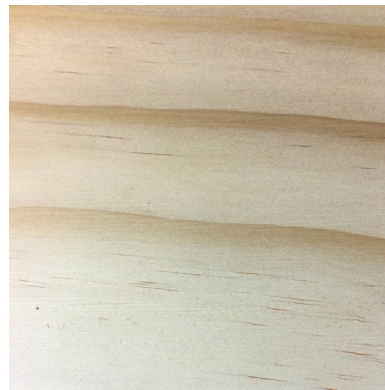

Natural



Accoya is the world's leading high technology long life wood. Accoya has properties that match or exceed those of the best tropical hardwoods and treated woods, yet is manufactured using wood from sustainable sources.