

Date	1993, modified in 2004	
Weights	C1	19.2 kg
	C2	27.5
	C3	29.0
	C4	31.7
	C5	27.2
	C6	26.2
	C7	23.1
Construction	frame: three-component system legs: 40 X 20 mm oval steel tubing, mitered corners rails: 40 X 20 mm square-section galvanized steel tubing; four per table leg sockets: die cast zinc alloy; one per leg tops: 19 mm chipboard adjustable glides	
Options	legs: polished chrome or powder coat tops: birch veneer or light grey decor laminate, with matching edge-banding stained birch veneer	
	linking devices for tops data & communication ports	

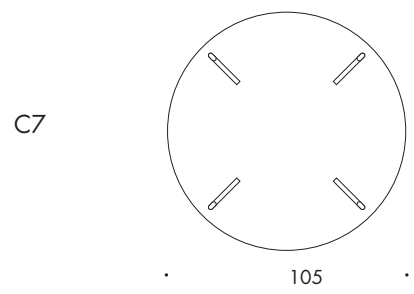

**Features & Benefits**

Component rail support system.....flexibility in sizes and planning  
 Legs specified separately.....sparkle & color where you see them  
 Wide variety of top sizes and finishes.....maximum project adaptability

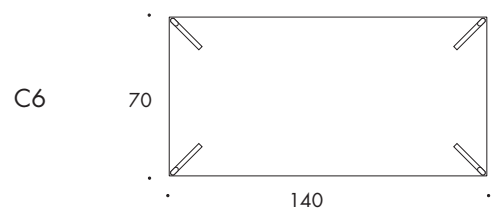
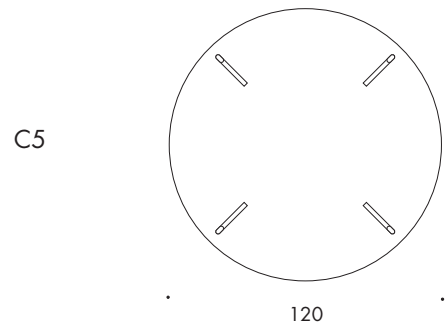
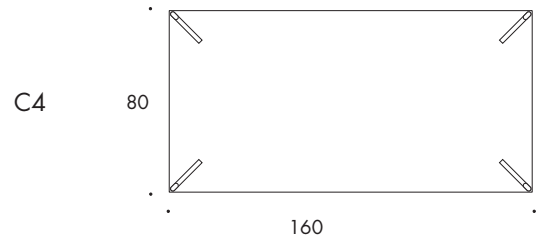
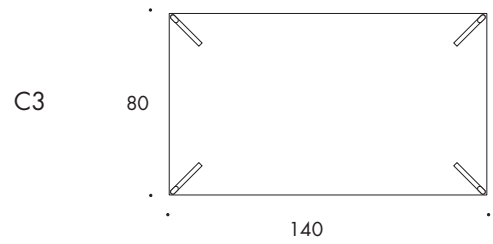
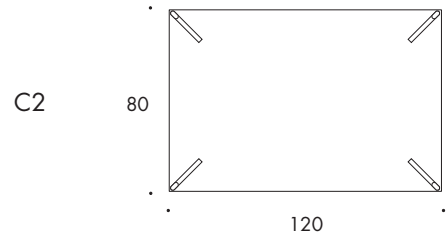
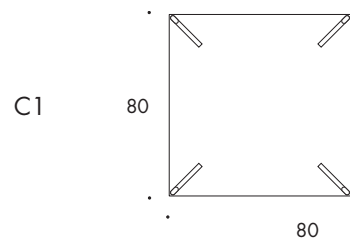
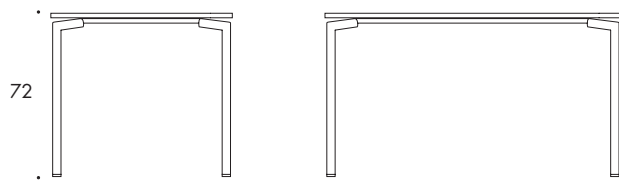



Date	2004		
Dimensions	C8	47.0	kg
	C9	42.0	
	C10	35.5	
	C11	47.5	
	C12	29.5	
	C13	45.5	

**Construction** component support construction consisting of:  
 rails: 40 X 20 mm square-section galvanized steel tubing  
 corner socket: die cast zinc alloy; one per leg  
 legs: 40 X 20 mm flat-oval section steel tubing  
 tops: 19 mm chipboard with face material  
 adjustable glides

**Options** legs: polished chrome or powder coat  
 tops: birch veneer with solid birch edge banding;  
 light grey decor laminate with ABS plastic edge banding;  
 stained birch veneer  
 linking devices for tops  
 data and communication port

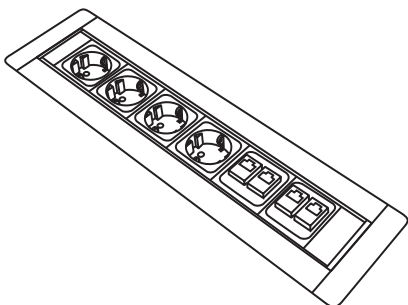
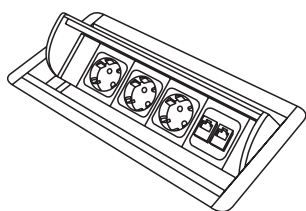

**Features & Benefits**

Component rail support system.....flexibility in sizes and planning  
 Legs specified separately.....sparkle & color where you see them  
 Wide variety of top sizes and finishes.....maximum project adaptability

C10

117

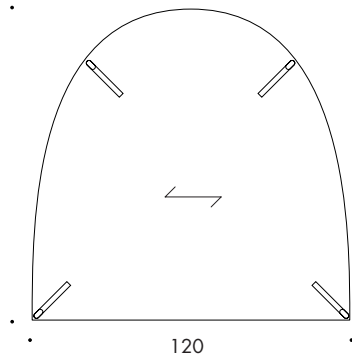

135

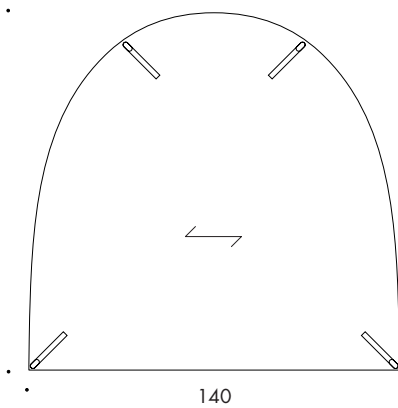

C11

C9

140

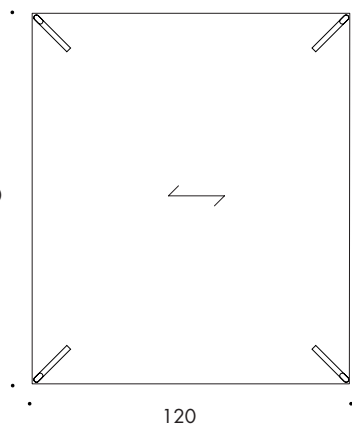

140

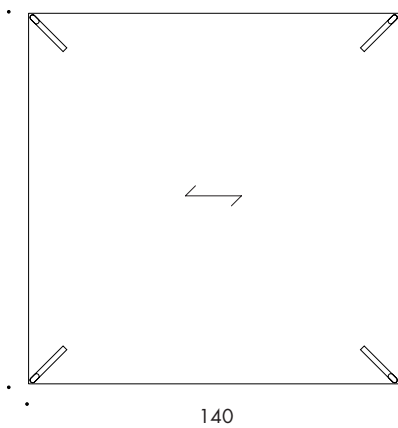

C8

C13

107

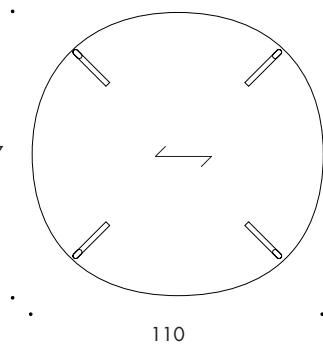

125

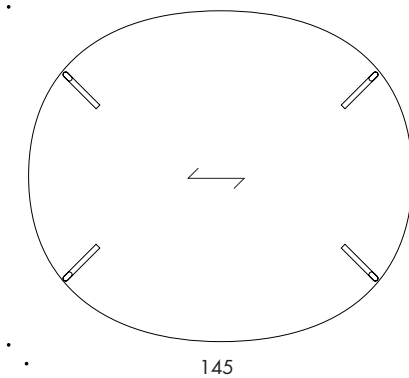

C12

