

SINCE 1945 • LAMMHULTS • SCANDINAVIAN DESIGN



LAMMHULTS

1945

PONTO

DESIGN TROELS GRUM-SCHWENSEN

- Ponto = Bridge in Esperanto. Esperanto is a language that has been constructed to work as an international language to help people understand between languages. The name of the language is a pseudonym, Doktoro Esperanto, in other words "a doctor with hope", just as the polish creator dr L.L Zamenhof 1859-1917.



The simplicity and character of the wooden legs gives a very distinct, warm and poetic expression, and the table can be seen as a truly innovative and renewing interpretation of the original Scandinavian functionalism. The pyramid-shaped legs, inclining in two directions, adds stability and character to PONTO, which has got its name from the bridge-like appearance coming from those inclined legs and the long span in between them.

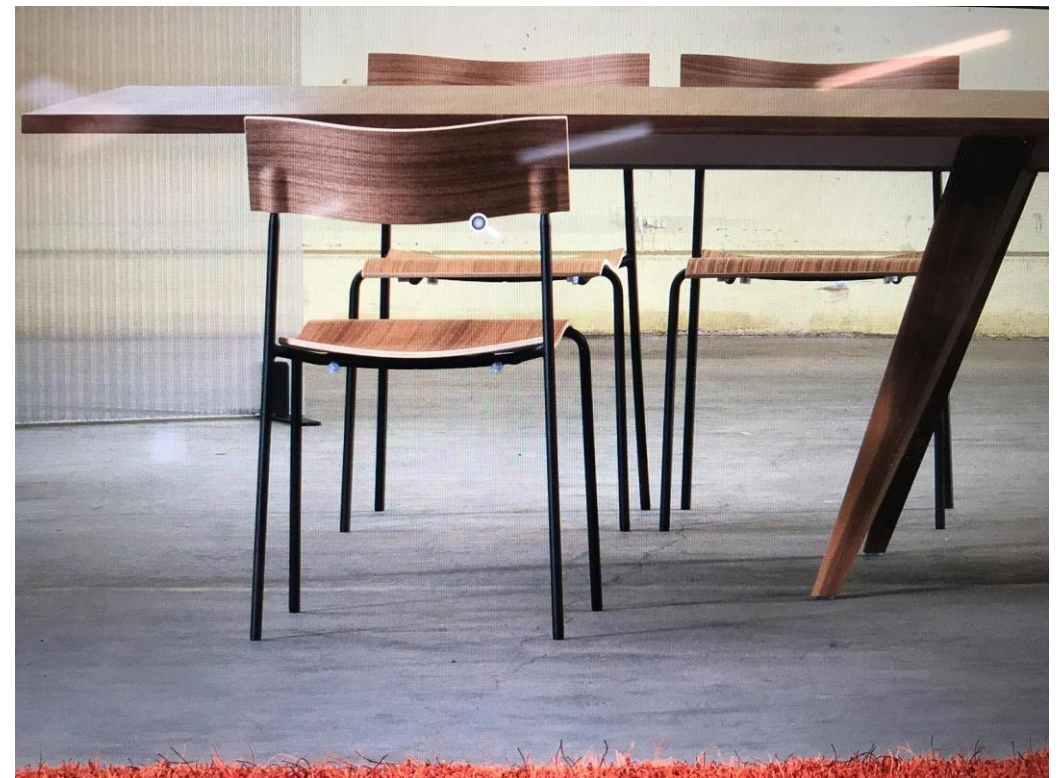

Exklusivität, Luxusgefühl, Authentisch



Construction:

Table top of 28mm thick table top of blockboard. The lamellas in the blockboard are vital to add stability for the connected tables. For the circular and the tables consisting of 1 table top the core is made in mdf.

Lengthwise rims in extruded aluminium fixed to the table top with screws.

Legs in solid ash (sustainable) or walnut.

Top surface in:

Veneer: Ash, Walnut and Oak, the veneer will be lengthwise for standard.

Linoleum: Desktop Forbo in colors Nero + Iron with edgeband black smoked oak as a standard.
Optional edge bands in Ash, Walnut and Oak.

The edge band in black smoked oak for the linoleum gives a monochrome appearance but still with a feeling of luxury.



Below shows the Logo casted into the end cap and the connection disc. These details are always in raw zinc finish.

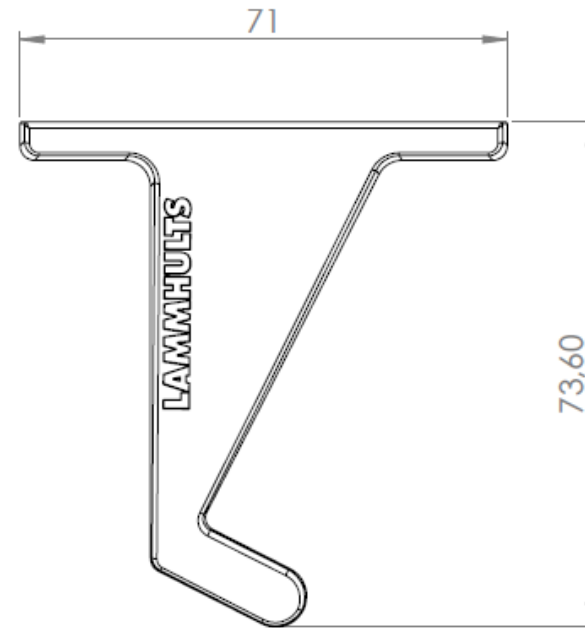
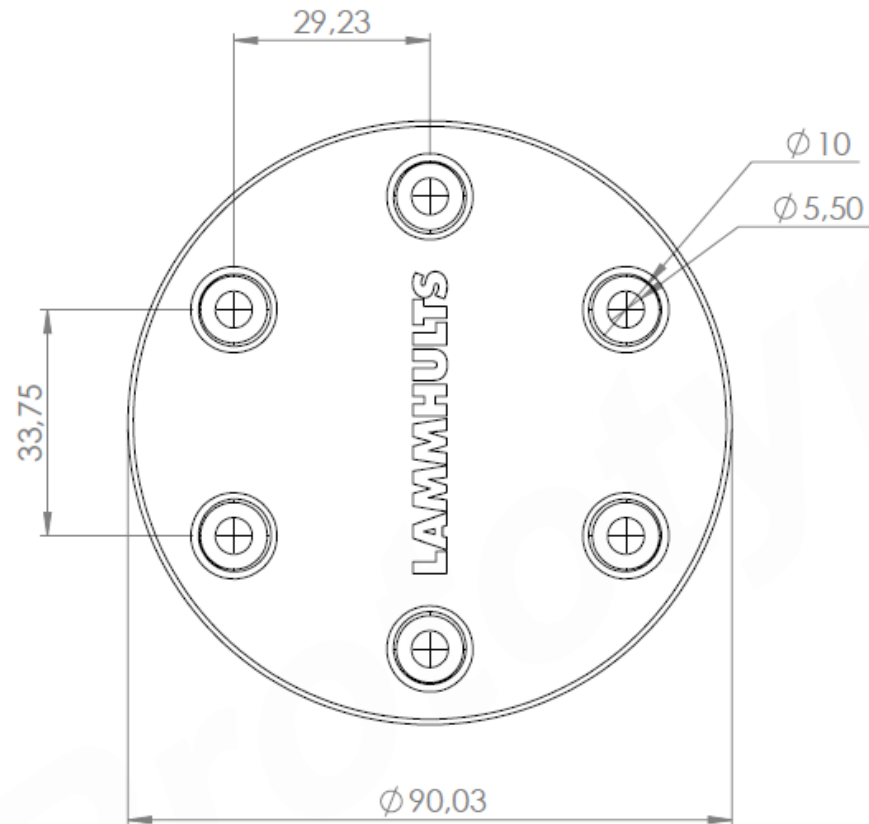

Drawing of the angled legs. The rectangular tables will always have 2 right and 2 left legs and not 4 legs of the same.

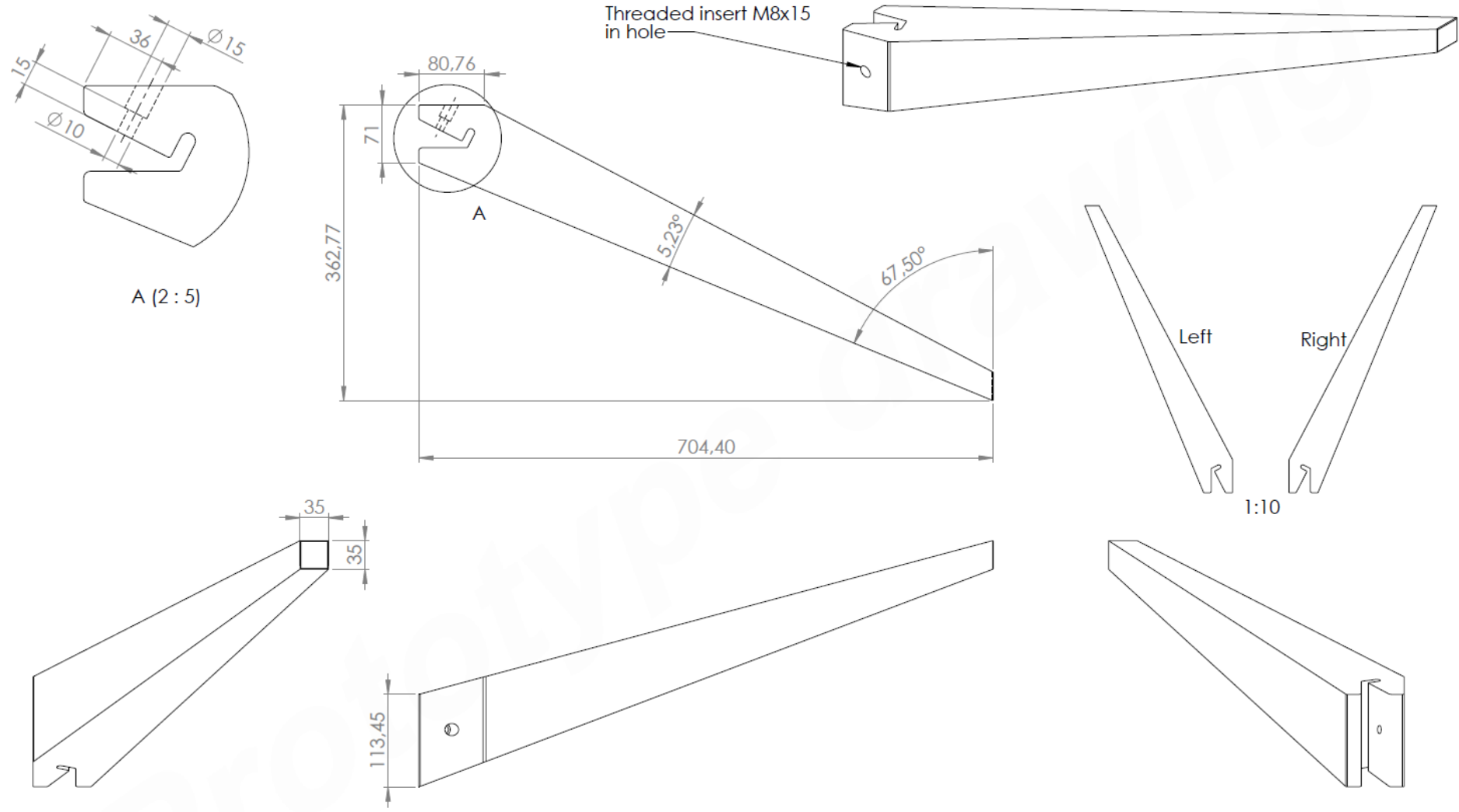

Drawing for the straight leg, only to be used for circular tables.

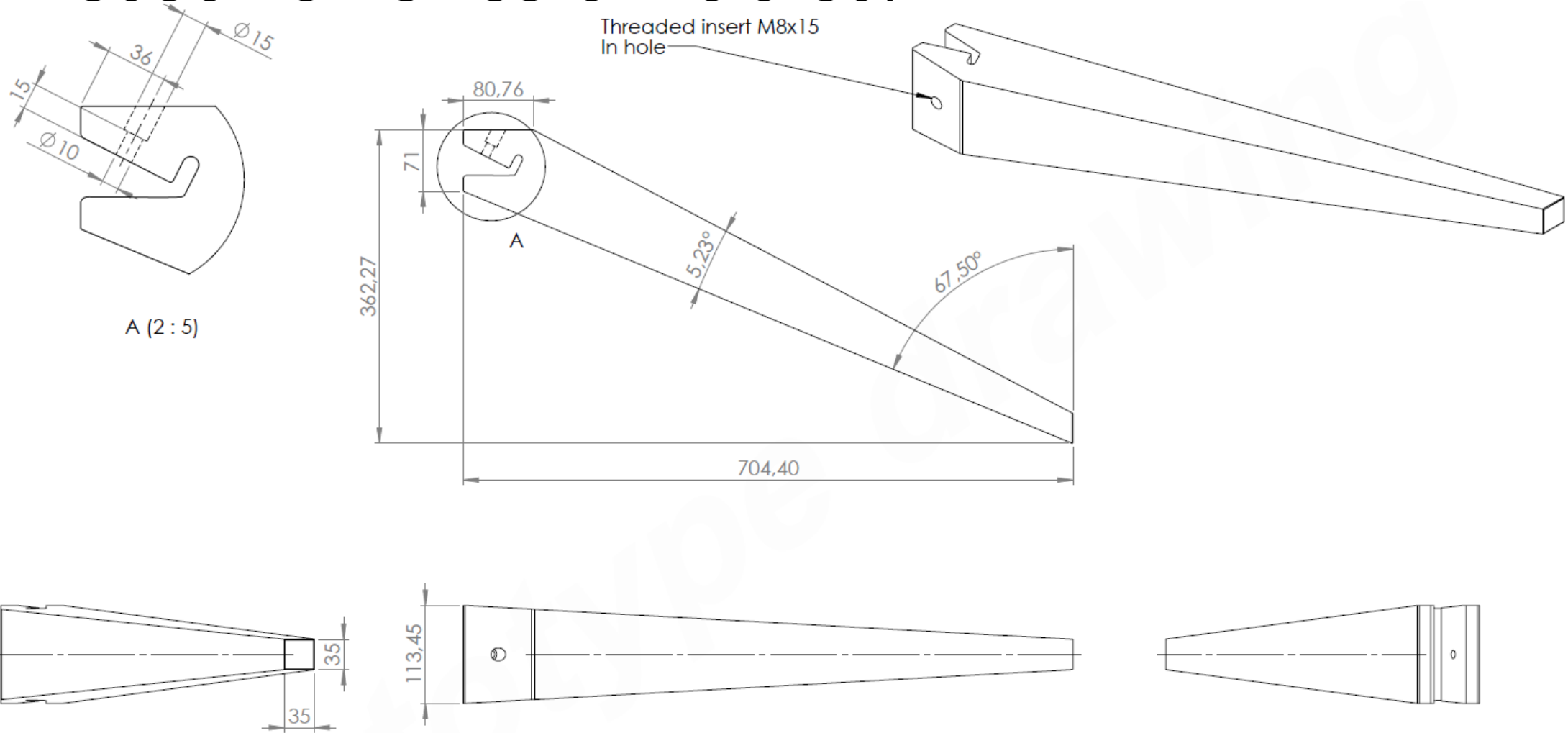

How to place the legs on a rectangular table.

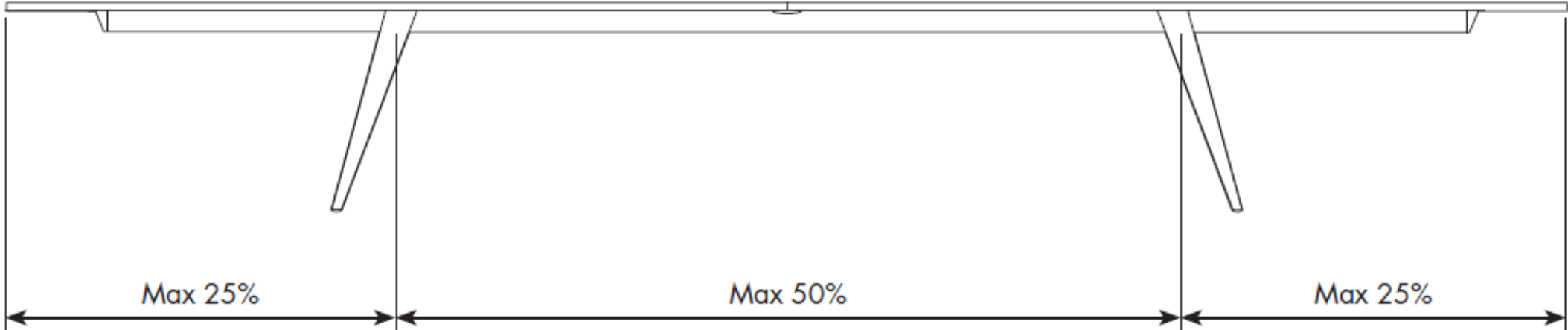

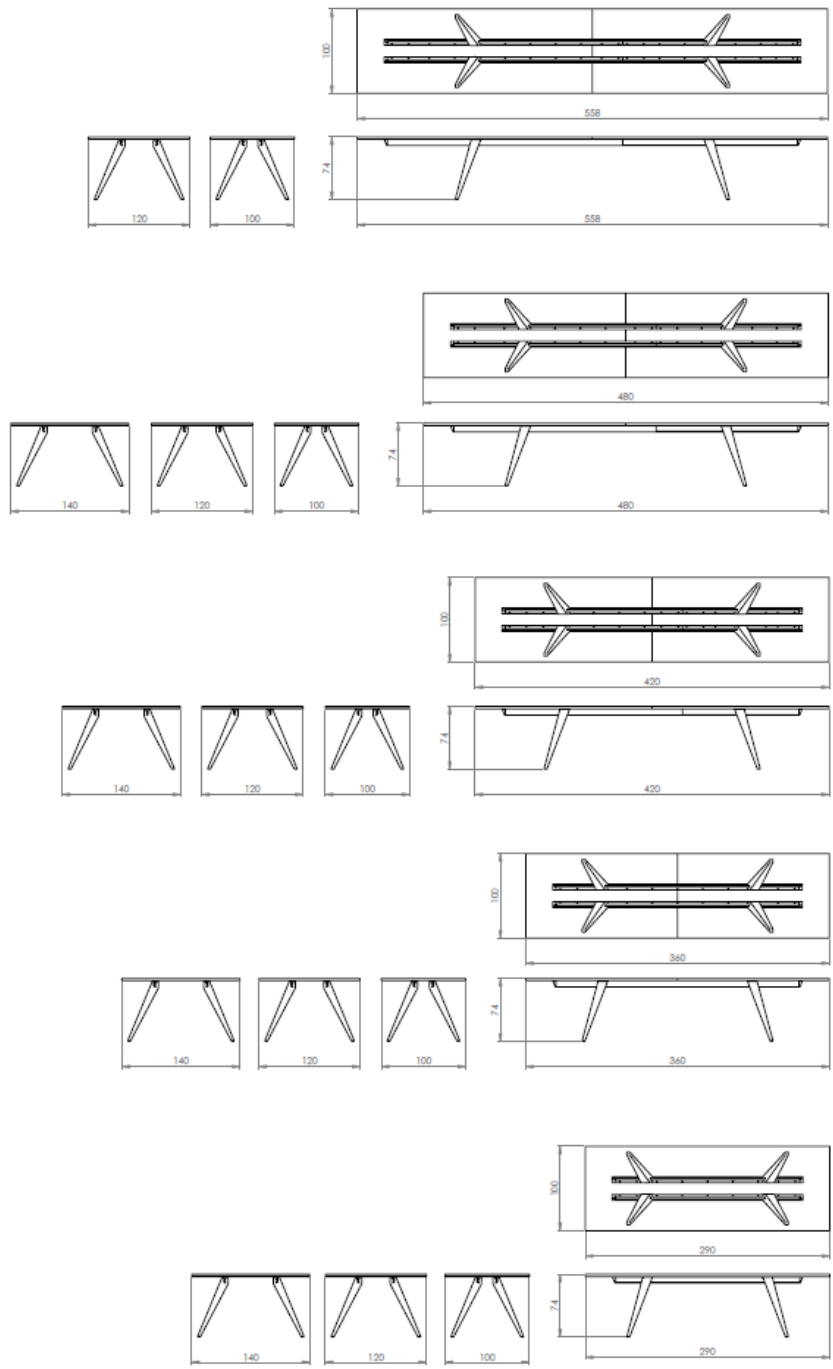

Sizes: Note: The longest table is not available in width 1400.

Height 740 mm
 Width 1000, 1200, 1400 mm
 1-table top 2900 mm d 1600 samt d 1800 mm
 2-table tops 3600mm 4200 mm 4800 mm 5580 mm

