



hm19 Reveal

A modular booth and privacy seating system designed to meet the flexible needs of our working environments. Reveal provides sanctuary for private working as well as space for collaboration.

The seating options are available in five seat widths with high or low back options and can be ordered as chairs and sofas with dual side panels, or configured into booth seating using the booth panels and tables.

Designed in house and made at our north London factory, Reveal offers the quality and meticulous detail that is synonymous with our established brand.

Power, charging and data units can be mounted in the table tops and presentation screens can be mounted on the booth panels.

For more information, [click here](#).



Robin Phillips studied Product Design at Ravensbourne College of Art and Industrial Design at the Royal College of Art. After working for Heals and Conran in furniture retail, he joined Hitch Mylius as General Manager in 2007. He became a Director in 2011 and took over ownership of the company in 2021.

His designs include the hm19 Reveal collection and the hm45 Juno chair and sofa, and he oversees the in-house product range as well as collaborating with external designers.



hm19k 3-seat sofa banquette seating

hm19e1 low 2-seat units with hm20i dining tables and hm22a armchairs





hm19a and m chairs with hm22a chairs

hm 19v desk booths and hm58h chairs with
5-star castor bases



hm19b single chair



hm19d 1.5 seat sofa



hm19f3 2-seat sofa with deep base
(deep base available on all sofas, chairs and booths)

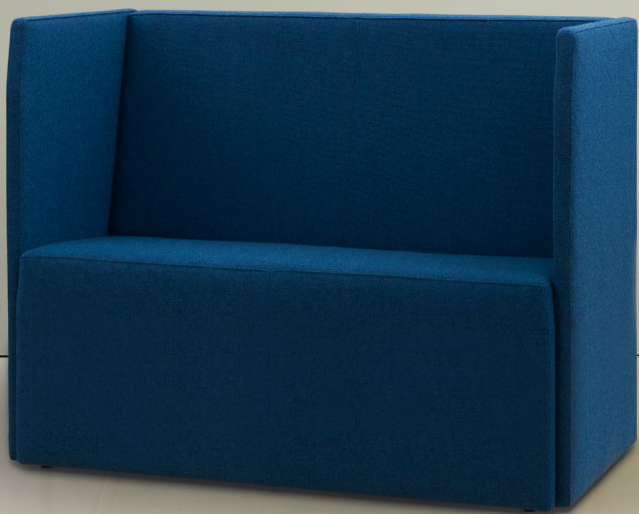

hm19k 3-seat sofa



hm19n high-back curved sofa with hm20s table



hm19e1 high booth



hm19d desk booth



hm19x1 desk pods with hm58i chairs



hm19e1 booth



hm **19f** booth
(closed booth panels available on all booths)



high back booth options

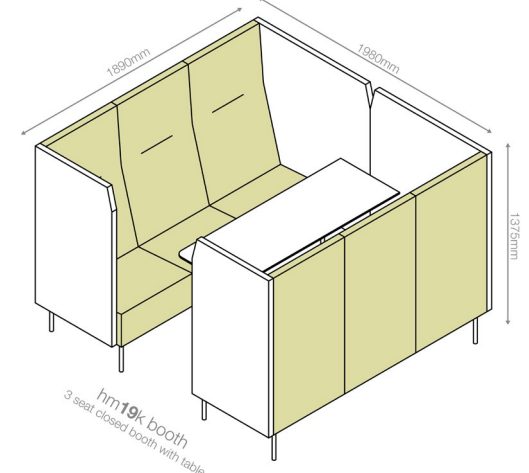
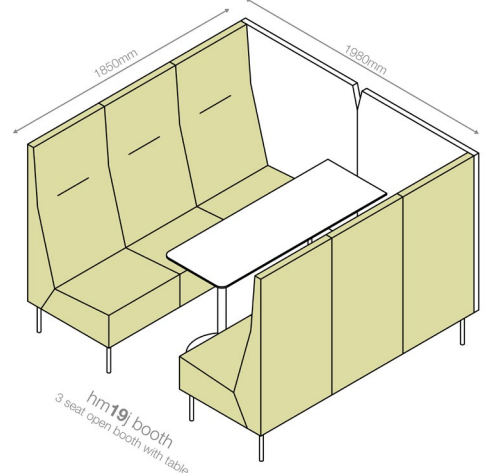
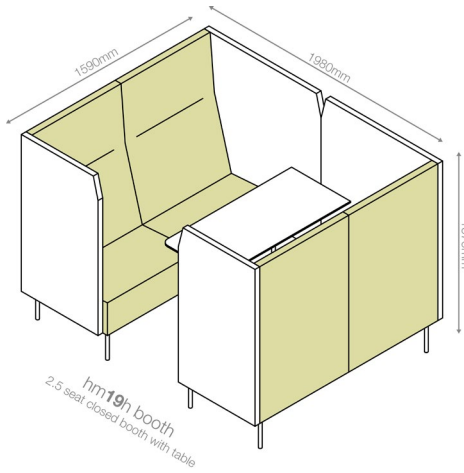
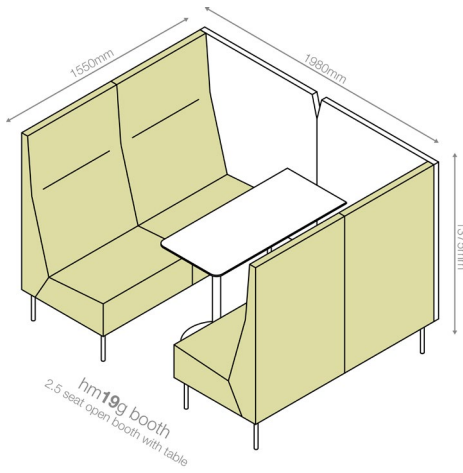
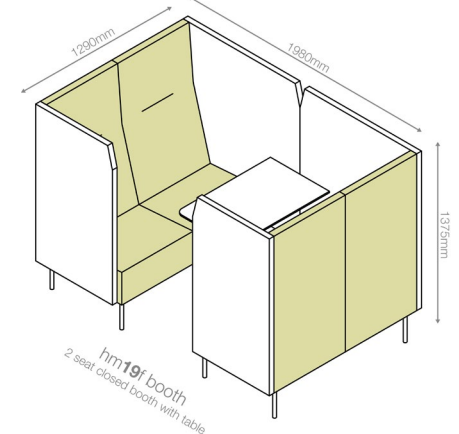
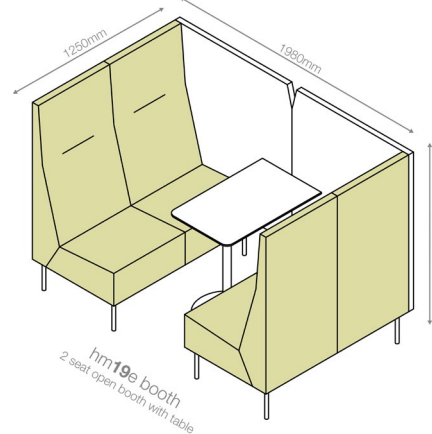
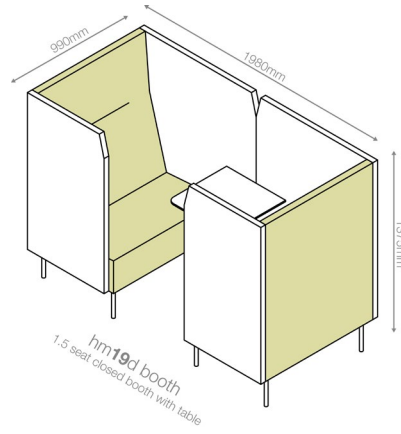
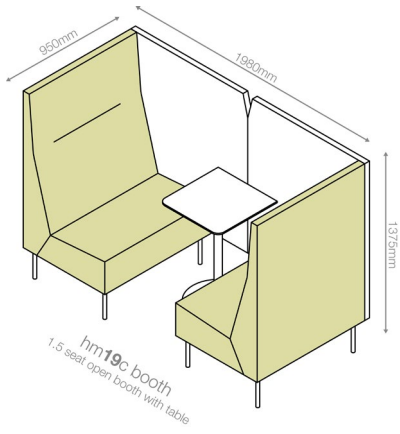

low back booth options

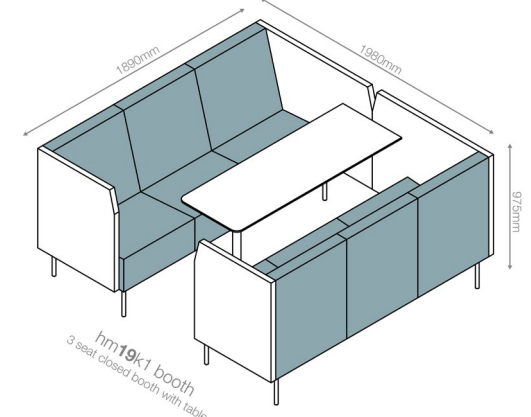
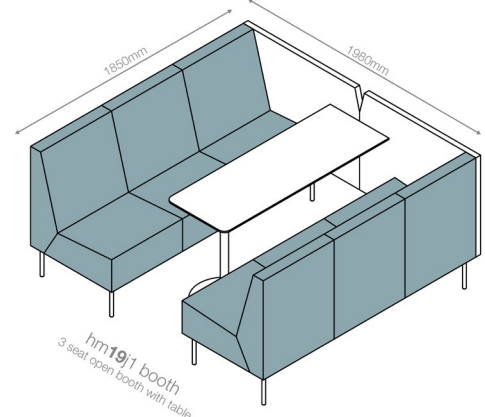
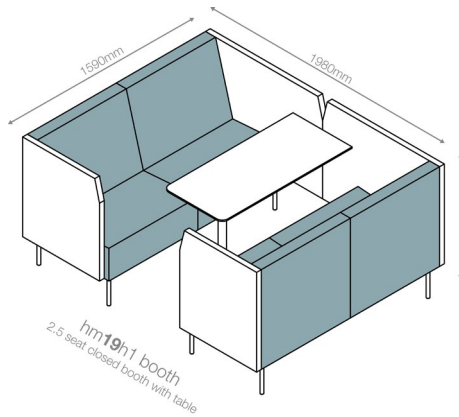
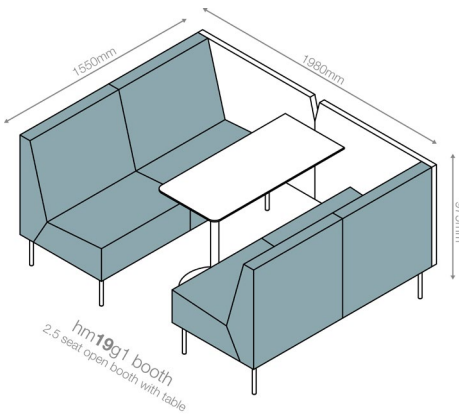
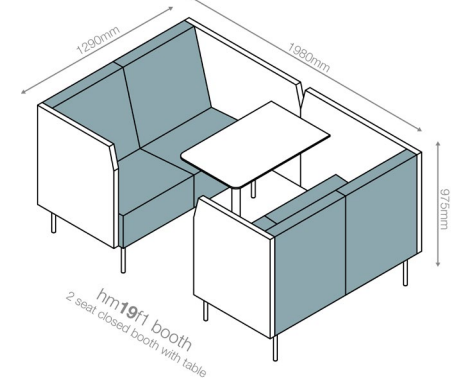
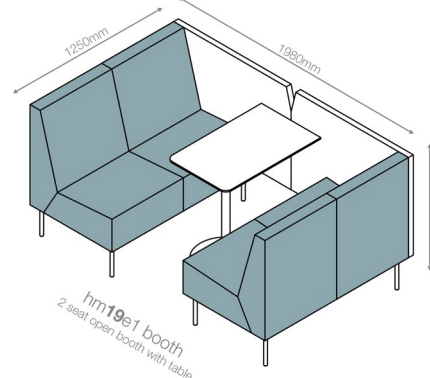
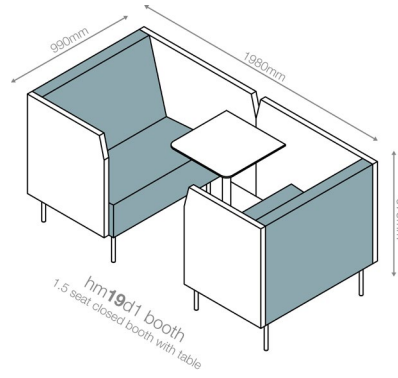
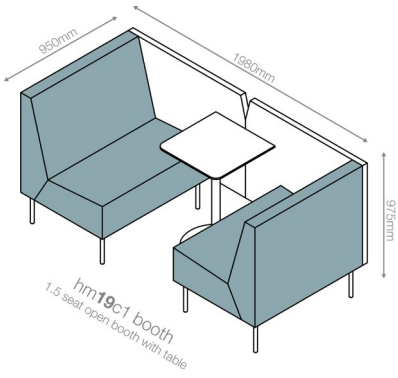

low back seat with high panel booth options

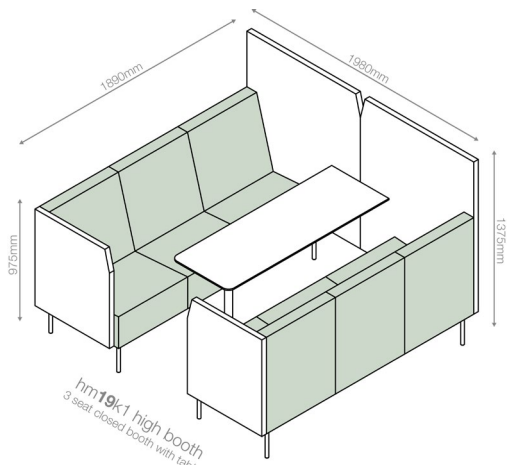
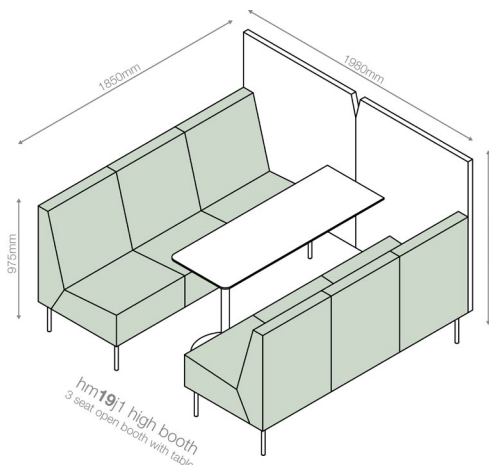
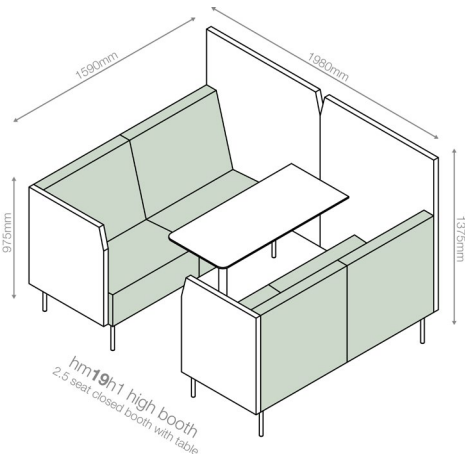
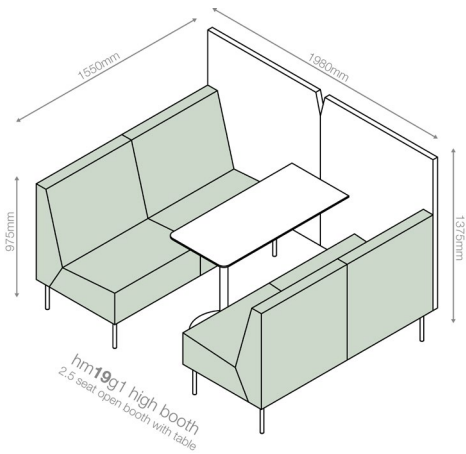
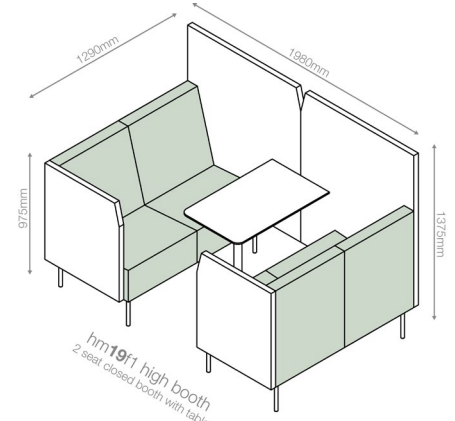
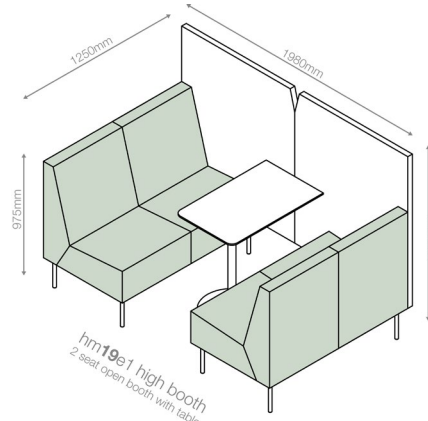
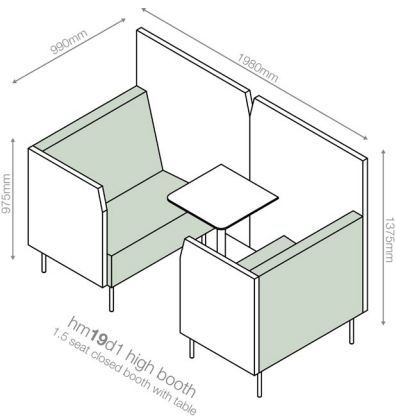
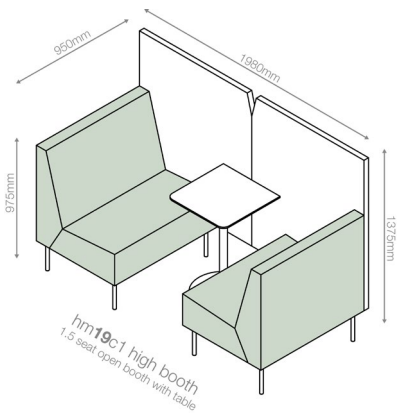

hm19 Reveal

design: Robin Phillips

w
d
h

w
d
h

w
d
h



19a

610
685
1375



19b3

690
685
975



19d1

990
685
975



19a1

610
685
975



19bx

690
685
1375



19d2

990
685
1375



19a2

610
685
1375



19c

910
685
1375



19d3

990
685
975



19a3

610
685
975



19c1

910
685
975



19e

1210
685
1375



19b

690
685
1375



19c2

910
685
1375



19e1

1210
685
975



19b1

690
685
975



19c3

910
685
975



19e2

1210
685
1375



19b2

690
685
1375



19d

990
685
1375



19e3

1210
685
975

Showroom
2nd floor
12 Greenhill Rents
London EC1M 6BN

Factory and HQ
Alma House
301 Alma Road
Enfield EN3 7BB

T +44 (0)20 8443 2616
E sales@hitchmylius.co.uk
visit hitchmylius.co.uk

hm19 Reveal

design: Robin Phillips

w
d
h

w
d
h

w
d
h



1290
685
19f 1375



1510
685
19g3 975

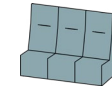

1810
685
19j2 1375



1290
685
19f1 975



1590
685
19h 1375

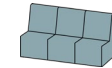

1810
685
19j3 975



1290
685
19f2 1375



1590
685
19h1 975



1890
685
19k 1375



1290
685
19f3 975



1590
685
19h2 1375

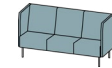

1890
685
19k1 975



1510
685
19g 1375



1590
685
19h3 975

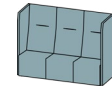

1890
685
19k2 1375



1510
685
19g1 975

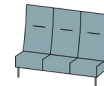

1810
685
19j 1375

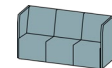

1890
685
19k3 975



1510
685
19g2 1375



1810
685
19j1 975



685
685
19m 1375

Showroom
2nd floor
12 Greenhill Rents
London EC1M 6BN

Factory and HQ
Alma House
301 Alma Road
Enfield EN3 7BB

T +44 (0)20 8443 2616
E sales@hitchmylius.co.uk
visit hitchmylius.co.uk

hm19 Reveal

design: Robin Phillips

w
d
h

w
d
h

w
d
h



19m1

685
685
975



19p

1300
1300
1375

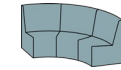

19q3

1640
1640
975



19m2

685
685
1375



19p1

1300
1300
975

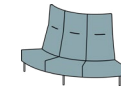

19r

1640
1640
1375



19m3

685
685
975



19p2

1300
1300
1375

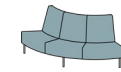

19r1

1640
1640
975



19n

1300
1300
1375



19p3

1300
1300
975

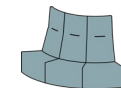

19r2

1640
1640
1375



19n1

1300
1300
975



19q

1640
1640
1375



19r3

1640
1640
975



19n2

1300
1300
1375



19q1

1640
1640
975



19s

40
650
1150



19n3

1300
1300
975

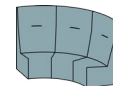

19q2

1640
1640
1375



19s1

40
650
750

Showroom
2nd floor
12 Greenhill Rents
London EC1M 6BN

Factory and HQ
Alma House
301 Alma Road
Enfield EN3 7BB

T +44 (0)20 8443 2616
E sales@hitchmylius.co.uk
visit hitchmylius.co.uk

















hm19 Reveal

design: Robin Phillips

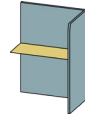
w
d
h

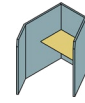
w
d
h

w
d
h

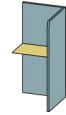
	40 650 1360	19s2		700 800 730	19u2		1480 990 1375	19w
	40 650 960	19s3		700 1100 730	19u3		1440 990 1375	19w1
	40 990 1150	19t		700 1400 730	19u4		1480 990 2000	19w2
	40 990 750	19t1		980 990 1375	19v		1440 990 2000	19w3
	40 990 1360	19t2		940 990 1375	19v1		1225 1620 1375	19x1
	40 990 960	19t3		980 990 2000	19v2		1225 1620 1375	19x2
	700 500 730	19u1		940 990 2000	19v3	seat height: 450		

Showroom
2nd floor
12 Greenhill Rents
London EC1M 6BN

Factory and HQ
Alma House
301 Alma Road
Enfield EN3 7BB

T +44 (0)20 8443 2616
E sales@hitchmylius.co.uk
visit hitchmylius.co.uk

hm19 Reveal environmental information modular booth seating by Robin Phillips

dimensions (mm)

width	610-1980
depth	685-1890
height	975/1375
seat depth	470
seat height	450

weight (kg) 16-132

facts and figures

- FSC-accredited solid beech and panel frame upholstered in cmhr foams
- can be finished in a wide choice of fabrics and hides
- RAL powder coated or metal plated steel legs or full length panel
- low VOCs; water-based glues only
- **30% recycled content**
- **70% recyclable content**



product contents (based on hm19k)

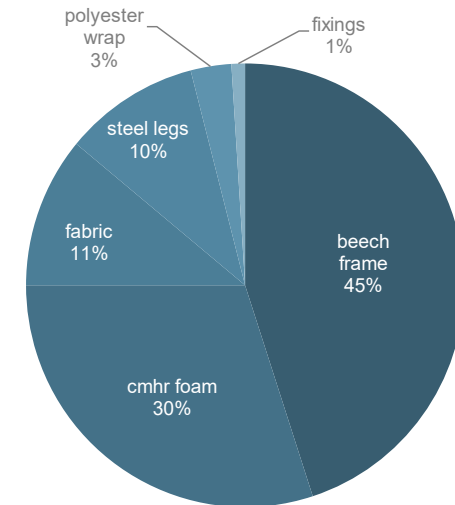

Hitch Mylius have been making beautiful and contemporary upholstered furniture in north London for over 50 years.

Our key environmental benefits include:

- ✓ Many of our key suppliers are local to us – our sofa frames and metalwork suppliers are 12 miles from our factory.
- ✓ We use water based glues.
- ✓ We use FSC certified timbers.
- ✓ It is our policy when dealing with waste to follow the waste hierarchy; prevent, reduce, reuse, recycle, recover.
- ✓ We are certified to BS EN ISO 14001:2015 and have been since October 2010.



Showroom
2nd floor
12 Greenhill Rents
London EC1M 6BN

Factory and HQ
Alma House
301 Alma Road
Enfield EN3 7BB

T +44 (0)20 8443 2616
E sales@hitchmylius.co.uk
visit hitchmylius.co.uk